



## SPECIFICATIONS

Estimate #: 1737  
Job Name: Mary Street Development, Building 3



# Unit 1, Bedroom 1 Ventilated

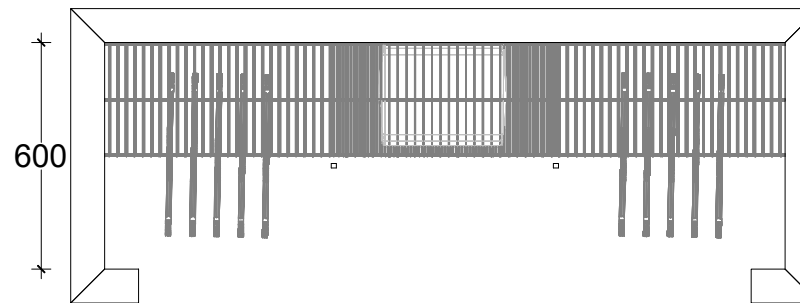
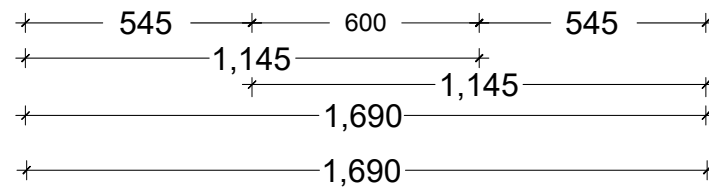
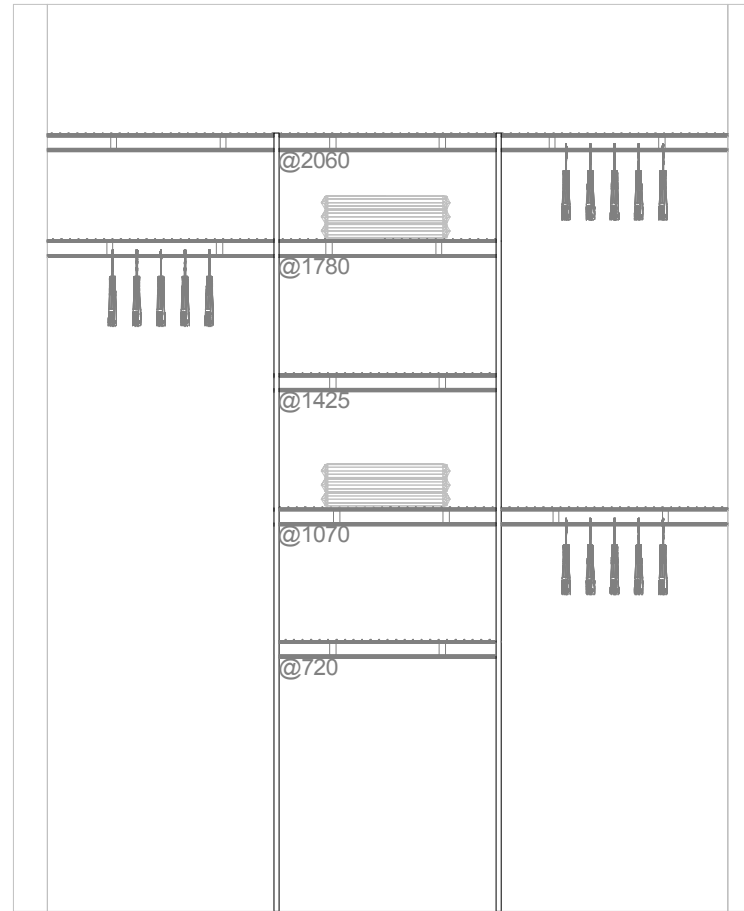

Designer Homeware (NZ) Ltd  
 0508 2 ORGANISE (67426)  
 www.designerhomeware.co.nz

**Job number:** 35524  
**Builder:** Iconic Construction  
**Owner/Client:** Building 3  
**Address:** Mary Street  
**City:** Hamilton  
**Quote number:** 131852

**Type:** 300S&R

All dimensions & size designations are subject to site verification and adjustment to fit job conditions. This is an original design and must not be released or copied unless an application fee has been paid or a job order placed.

**5.18 Metres 2 Pole**

Plans and Specifications Approved:

Date: .....

# Unit 1, Bedroom 2 Ventilated

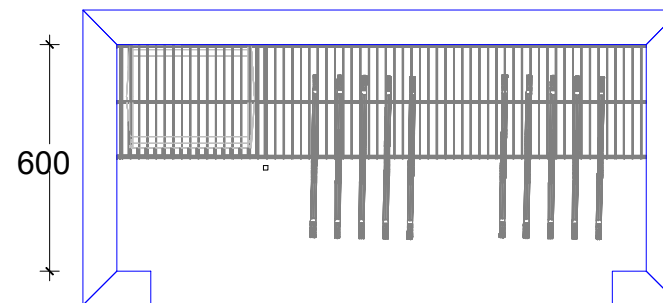
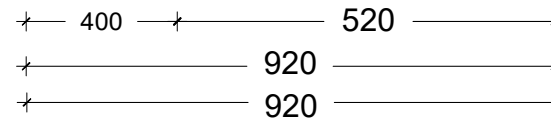
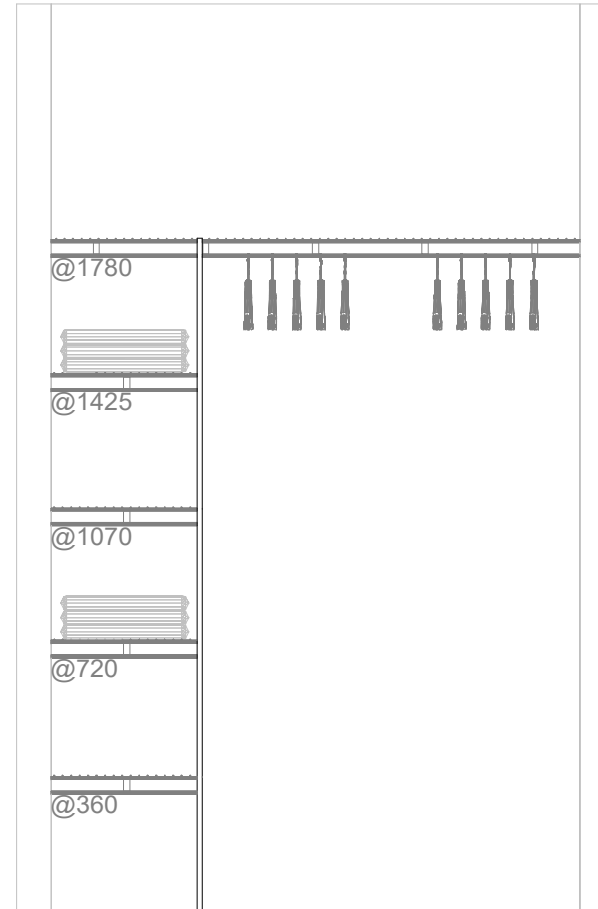

Designer Homeware (NZ) Ltd  
0508 2 ORGANISE (67426)  
www.designerhomeware.co.nz

**Job number: 35524**  
**Builder: Iconic Construction**  
**Owner/Client: Building 3**  
**Address: Mary Street**  
**City: Hamilton**  
**Quote number: 131852**

**Type: 300 S&R**

All dimensions & size designations are subject to site verification and adjustment to fit job conditions. This is an original design and must not be released or copied unless an application fee has been paid or a job order placed.

**2.52 Metres 1 Pole**

Plans and Specifications Approved:

Date: .....

# Unit 1, Bedroom 3 Ventilated

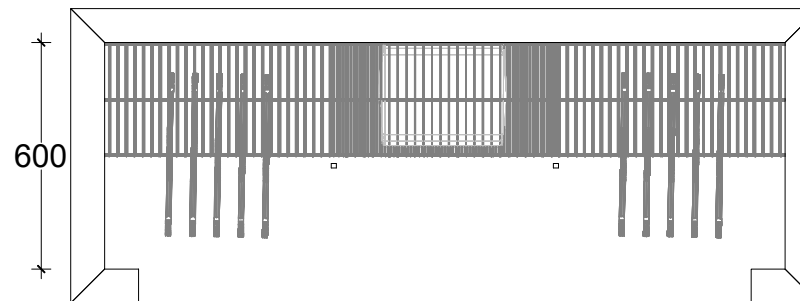
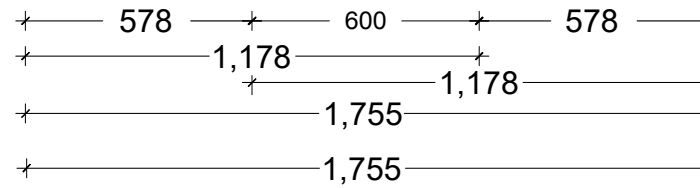
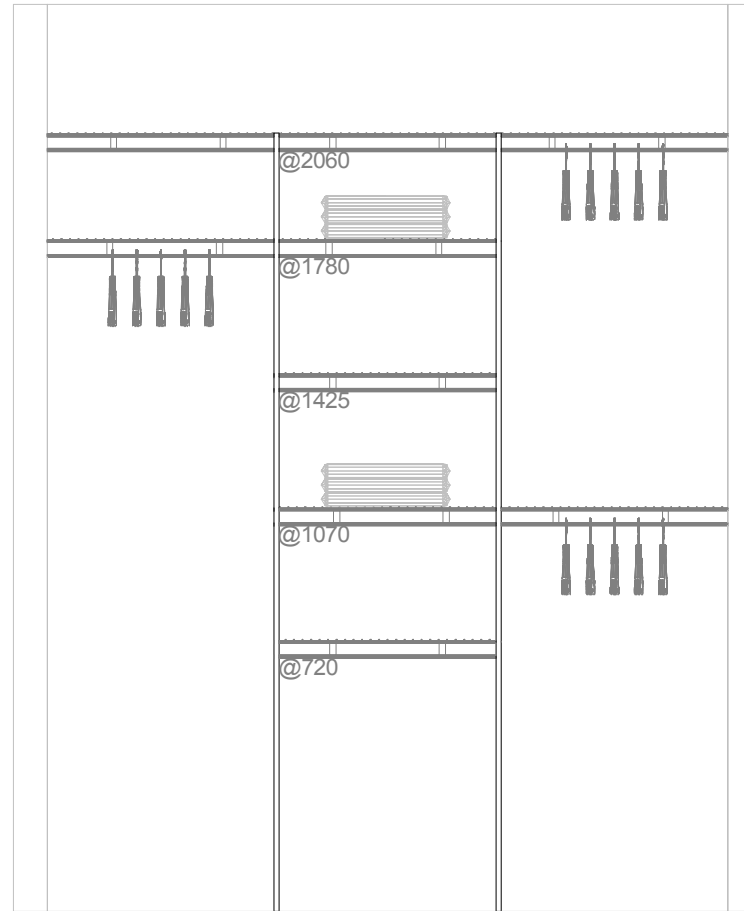

Designer Homeware (NZ) Ltd  
0508 2 ORGANISE (67426)  
www.designerhomeware.co.nz

**Job number:** 35524  
**Builder:** Iconic Construction  
**Owner/Client:** Building 3  
**Address:** Mary Street  
**City:** Hamilton  
**Quote number:** 131852

**Type:** 300S&R

All dimensions & size designations are subject to site verification and adjustment to fit job conditions. This is an original design and must not be released or copied unless an application fee has been paid or a job order placed.

**5.31 Metres 2 Pole**

Plans and Specifications Approved:

Date: .....



# Unit 2, Bedroom 1 Ventilated

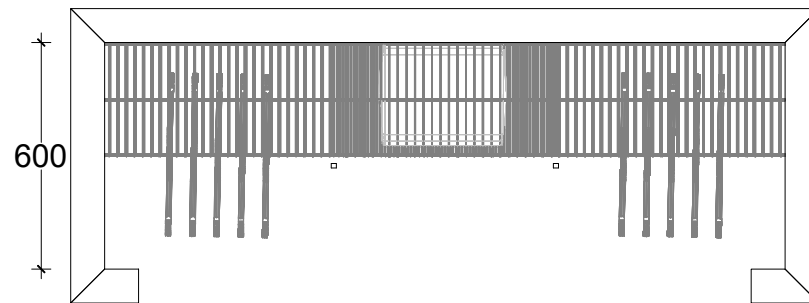
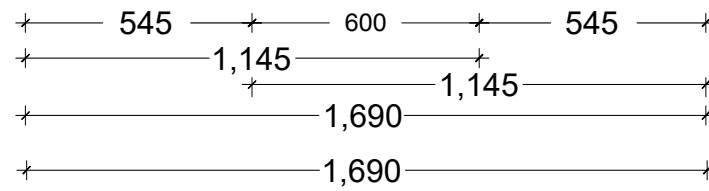
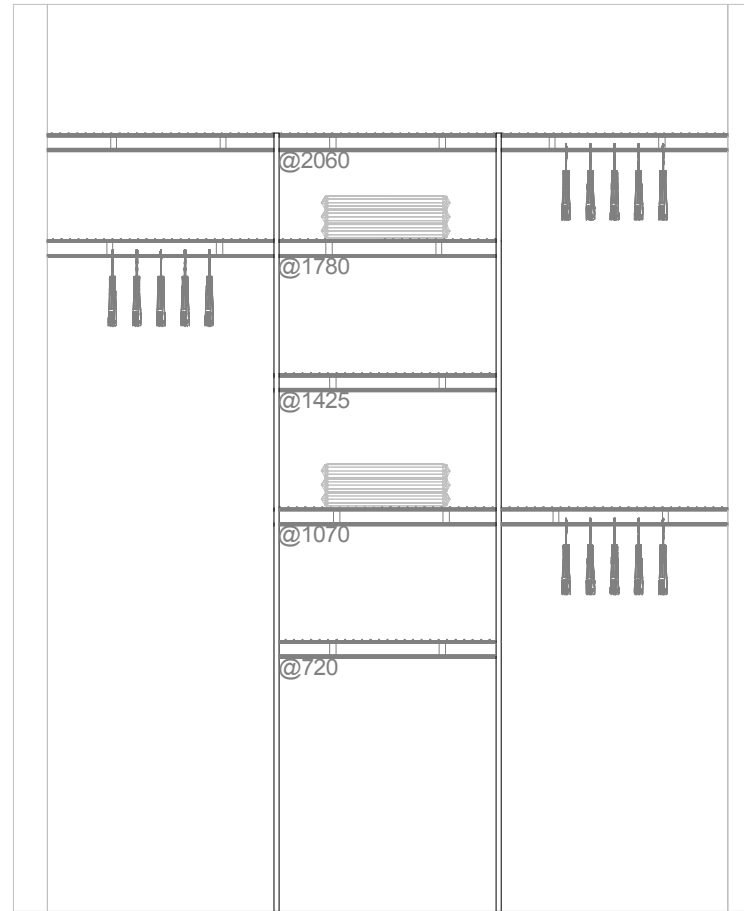

Designer Homeware (NZ) Ltd  
0508 2 ORGANISE (67426)  
www.designerhomeware.co.nz

**Job number:** 35524  
**Builder:** Iconic Construction  
**Owner/Client:** Building 3  
**Address:** Mary Street  
**City:** Hamilton  
**Quote number:** 131852

**Type:** 300S&R

All dimensions & size designations are subject to site verification and adjustment to fit job conditions. This is an original design and must not be released or copied unless an application fee has been paid or a job order placed.

**5.18 Metres 2 Pole**

Plans and Specifications Approved:

Date: .....

# Unit 2, Bedroom 2 Ventilated

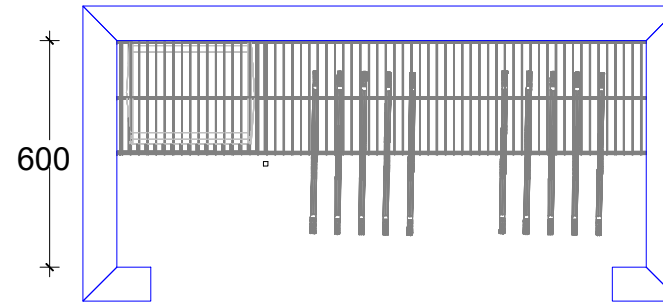
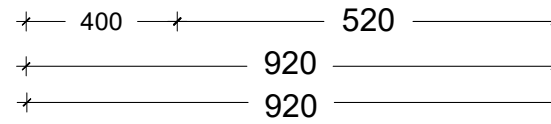
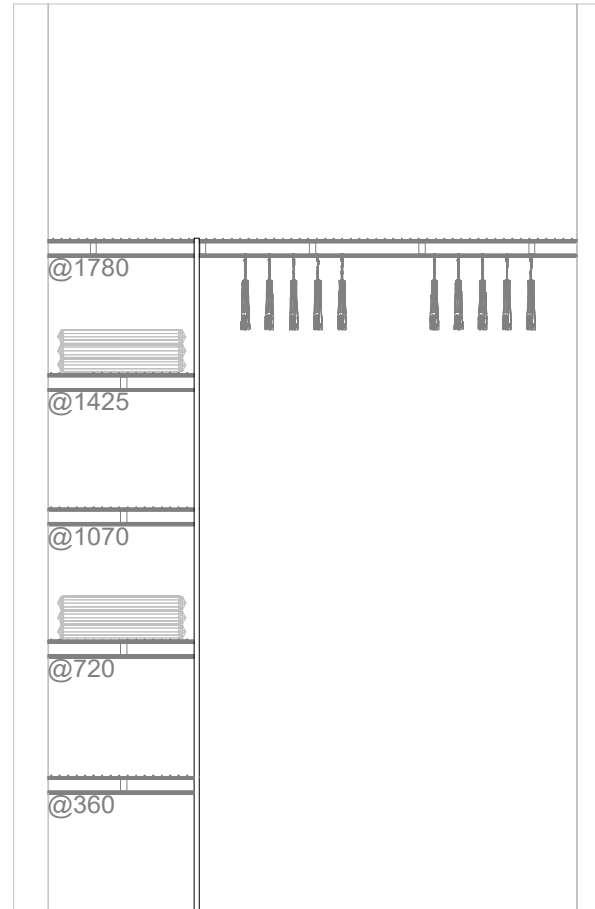

Designer Homeware (NZ) Ltd  
0508 2 ORGANISE (67426)  
www.designerhomeware.co.nz

**Job number: 35524**  
**Builder: Iconic Construction**  
**Owner/Client: Building 3**  
**Address: Mary Street**  
**City: Hamilton**  
**Quote number: 131852**

**Type: 300 S&R**

All dimensions & size designations are subject to site verification and adjustment to fit job conditions. This is an original design and must not be released or copied unless an application fee has been paid or a job order placed.

**2.52 Metres 1 Pole**

Plans and Specifications Approved:

Date: .....

# Unit 2, Bedroom 3 Ventilated

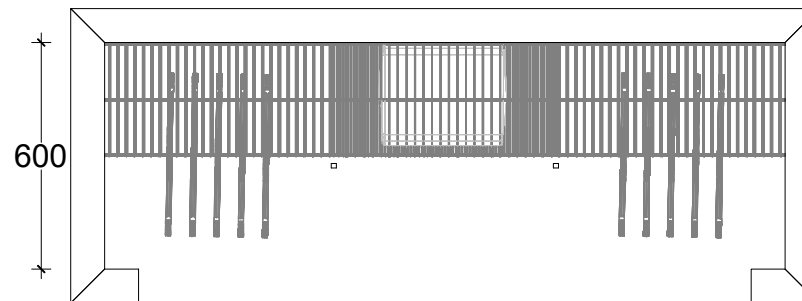
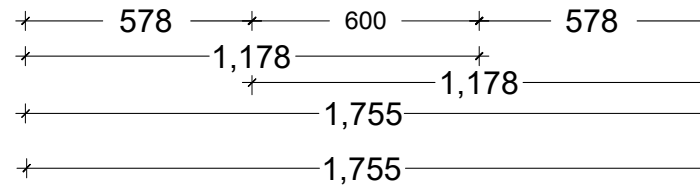
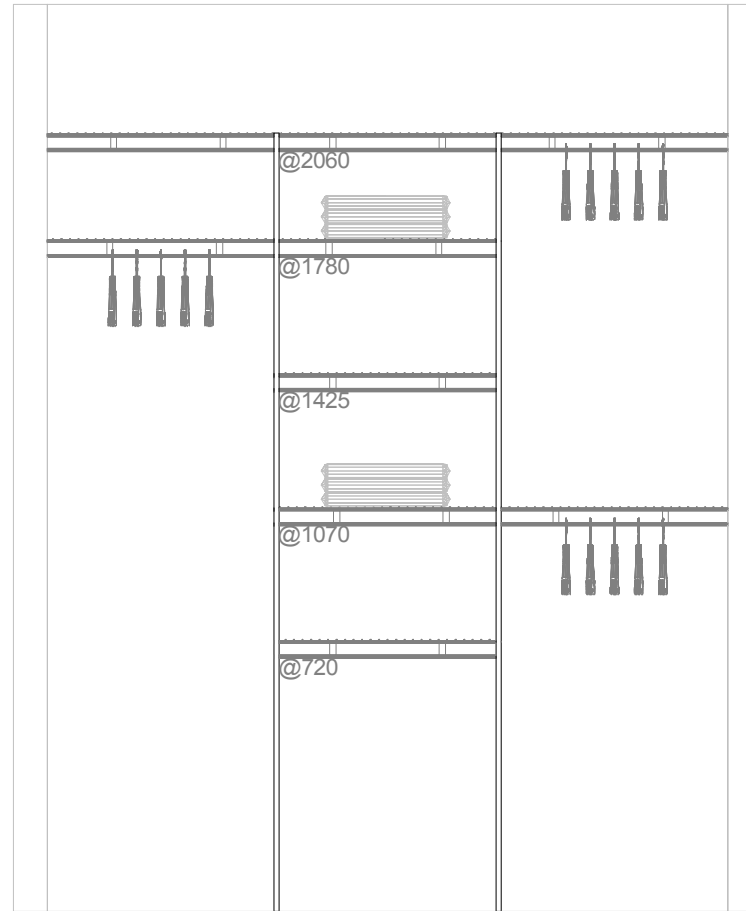

Designer Homeware (NZ) Ltd  
0508 2 ORGANISE (67426)  
www.designerhomeware.co.nz

**Job number:** 35524  
**Builder:** Iconic Construction  
**Owner/Client:** Building 3  
**Address:** Mary Street  
**City:** Hamilton  
**Quote number:** 131852

**Type:** 300S&R

All dimensions & size designations are subject to site verification and adjustment to fit job conditions. This is an original design and must not be released or copied unless an application fee has been paid or a job order placed.

**5.31 Metres 2 Pole**

Plans and Specifications Approved:

Date: .....

## DWA6314X2

Dishwashers, Universale, Free-standing, 60 cm, Number of place settings: 14, Silver

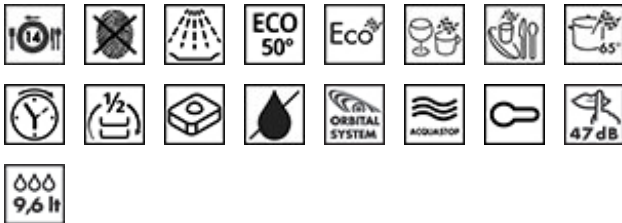

### TYPE

Product Family: Dishwashers • Commercial height: 85 cm • Number of place settings: 14 • Installation: Free-standing • Commercial width: 60 cm • EAN code: 8017709278847

### AESTHETICS

Color: Silver • Finishing: Fingerproof • Aesthetics: Universale • Front panel colour: Silver (opal grey) • Door type: Without frame • Door colour: Finger friendly stainless steel • Sides colour: Silver (opal grey) • Top colour: Silver (opal grey) • Plinth colour: Silver (opal grey) • LED/display colour: White • Buttons colour: Silver (opal grey)

### PROGRAMS / FUNCTIONS

N. of programmes: 5+5 quick programmes • Soak: Yes • Rapid 27': Yes • ECO: Yes • Ultraclean: Yes • ECO Quick: Yes • Delicate and Quick: Yes • Daily Quick: Yes • Strong and fast: Yes • Intensive 65°: Yes • Normal ECO: Yes • Washing temperatures: 38, 45, 50, 65, 70 °C

## OPTIONS

Delay timer option: 3-6-9-12 hours • 1/2 load FlexiZone option: Yes • Options for tabs FlexiTabs: Yes • Quick Time option: Yes

## BASKETS

N° baskets: 3, Flexi • Basket colour: Grey • Basket components colour: Grey • Handle: In plastic with stainless steel insert on upper and lower basket • Upper Basket: With central fixed racks • Height adjustment of the upper basket: On three levels • Lower Basket: With 4 foldable racks • Largest loadable dish in upper basket: 19,0 cm • Lower basket with anti-drip inserts: Yes • Largest loadable dish in lower basket: 30,0 cm • Cutlery basket: 13 place settings sliding • Colour Inner Components: Blue

## TECHNICAL FEATURES

Controls: Electronic • Display: Delayed start • On/off indicator: Yes • Rinse aid indicator: Light • Progress indicator: Yes • End of cycle indicator: On display, with acoustic signal • Washing system: Orbital • Drying system: Natural condenser drying • Motor: Single phase • Third spray arm: Single • Flood protection system: Total Acquastop • Water supply: Single; cold/hot water max. 60°C - energysave with hot water up to 35% • Max water hardness: 100°FH;58°dH • Child safety system (door lock): Yes • Tub material: Stainless steel • Filter: Stainless steel • Concealed heating element: Yes • Hinges: Self balancing with fixed hinges • Adjustable feet: Just for levelling

## PERFORMANCE / ENERGY LABEL

Noise level: 47 dB(A) re 1pW • Water consumption per cycle (l/cycle): 9.6 l • Annual energy consumption: 243 kWh/a • Reference programme: Normal ECO • Total cycle time of reference programme (min): 140 min • Duration of the stand by on mode (min): 5 min • Energy Label ex EU: Energy rating: 3,5 stars - Water rating: 5,5 stars

## ELECTRICAL CONNECTION

Connected power: 1800 W • Voltage: 220-240 V • Type of connection: Single-phase • Frequency (Hz): 50 Hz • Power supply cable length: 140 cm

## FEATURES ATTRIBUTES

Noise level: 45 - 47 dB(A)

## ALSO AVAILABLE

## LOGISTIC INFORMATION

Dimensions of the product HxWxD (mm): 848x598x600 • Net weight (kg): 55.000 kg

## SE364TD

60cm Touch Control Ceramic  
Hob with Straight Edge Glass

EAN13: 8017709234720

- 4 "High-light" radiant cooking zones
- Rear Left: Ø 148mm, 1.20 kW
- Front Left : Ø 184mm, 1.80 kW
- Rear Right : Ø 184mm, 1.80 kW
- Front Right : Ø 148mm, 1.20 kW
  
- Black ceramic glass
- 9 power levels
- End of cooking acoustic alarm
- Quick start
- Keep warm automatic function
- Residual heat indicators
- Ecologic – Energy saving option
- Child safety lock
- Automatic safety cut-out
  
- Nominal power: 6.00 kW

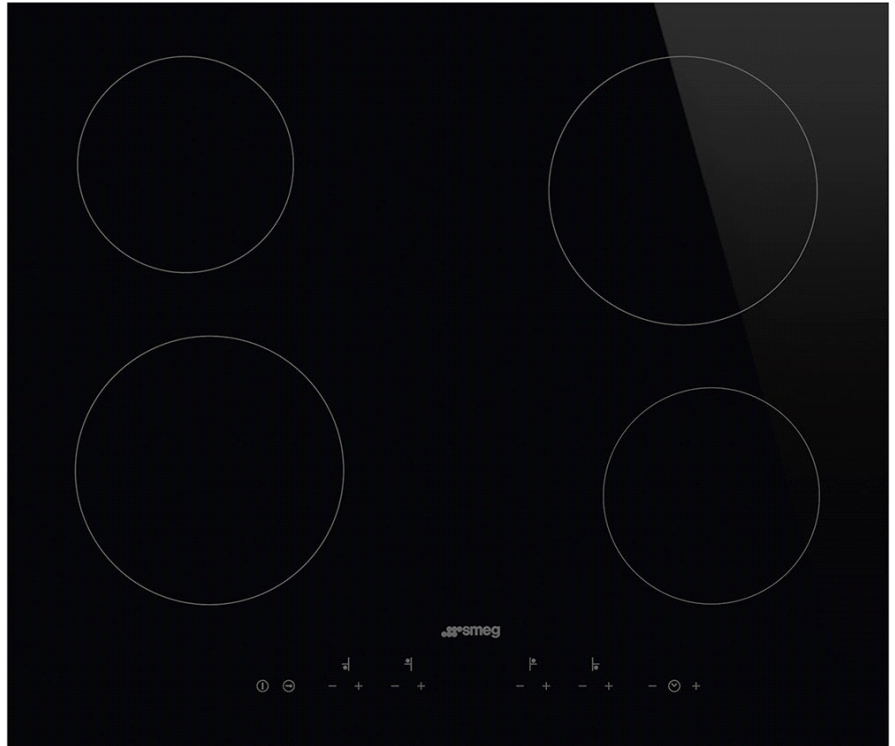





# SE364TD

ceramic hob  
60 cm  
black  
touch control

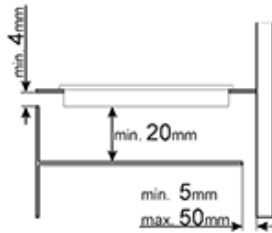
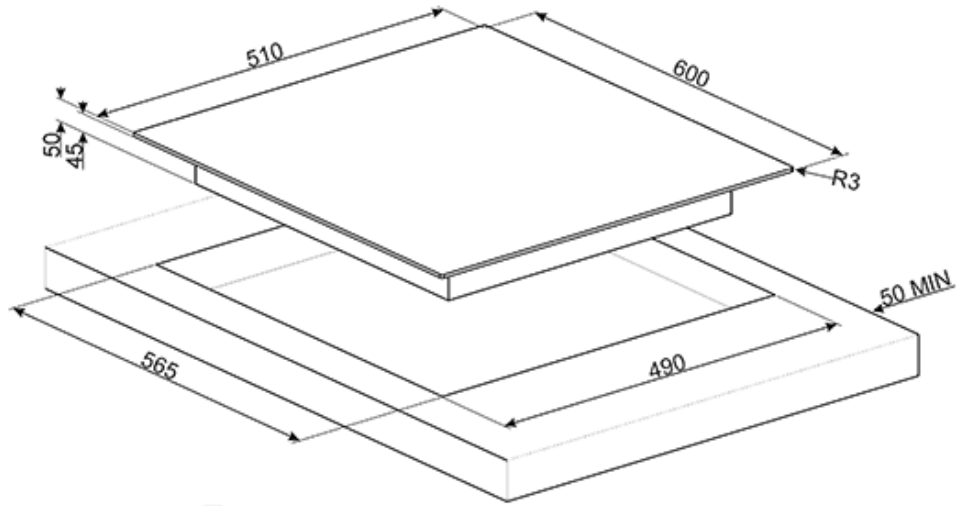

Smeg (UK) Ltd  
The Magna Building, Wyndyke Furlong, Abingdon  
OX14 1DZ  
Tel. +44 (0)844 557 9907  
Fax +44 (0)844 557 9337

## SFA6500TVX

Oven, Classic, 60cm, Thermoseal, Stainless steel, Vapour Clean

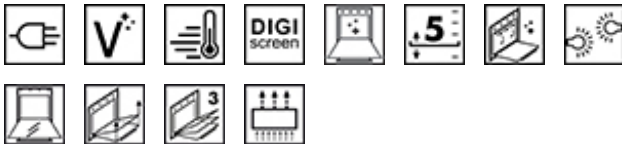

### TYPE

Product Family: Oven • Category: 60cm • Cooking Method: Thermoseal • Power supply: Electric • EAN code: 8017709286361 •  
Cleaning system: Vapour Clean

### AESTHETICS

Colour: Stainless steel • Finishing: Fingerproof • Aesthetic: Classic • Material: Stainless steel • Type of steel: Brushed • Glass  
Type: Eclipse • Door: With 1 horizontal strip • Handle: Classic • Handle Colour: Inox

### PROGRAMS / FUNCTIONS

No. of cooking functions: 8 • Traditional cooking functions: Static, Fan assisted, Circulaire, Turbo, Eco, Large grill, Fan grill (large),  
Base • Other functions: Defrost • Cleaning functions: Vapour Clean

### CONTROLS

Display: Yes • Control setting: Knobs & buttons • No. of controls: 2 • Control knobs: Classic

## OPTIONS

Time-setting options: Delay start and automatic end cooking • Minute minder: Yes • Timer: 1 • Rapid pre-heating: Yes

## TECHNICAL FEATURES

Display name: DigiScreen • Display technology: LED • Temperature control: Electro-mechanical • Minimum Temperature: 50 °C • Maximum temperature: 250 °C • Cavity material: Ever clean Enamel • No. of shelves: 5 • Shelves type: Metal racks • Tilting grill: Yes • N. of fans: 1 • No. of lights: 1 • User-replaceable light: Yes • Light type: Halogen • Light Power: 40 W • Light when door is opened: Yes • Door opening type: Standard opening • Door: Temperate door • Removable door: Yes • Full glass inner door: Yes • Removable inner door: Yes • Total no. of door glasses: 3 • Safety Thermostat: Yes • Cooling system: Tangential • Heating suspended when door is opened: Yes • Lower heating element power: 1200 W • Upper heating element - Power: 1000 W • Grill element - power: 1700 W • Large grill - Power: 2700 W • Circular heating element - Power: 2000 W

## PERFORMANCE / ENERGY LABEL

## ELECTRICAL CONNECTION

Voltage: 220-240 V • Nominal power: 3000 W • Frequency (Hz): 50/60 Hz • Power supply cable length: 115 cm

## LOGISTIC INFORMATION

Dimensions of the product (mm): 592x597x548 • Net weight (kg): 35.100 kg

## ACCESSORIES INCLUDED

Rack with back and side stop: 1 Enamelled tray (20mm): 1 Enamelled deep tray (40mm): 1 Insert grid: 1

## OPTIONAL

PPR2: Pizza stone

## SHW610X1 60CM WALLMOUNT CANOPY RANGEHOOD



EAN 9345025001740

Finish	Stainless steel
Dimensions	600mmW x 640–1030mm H x 470mmD
Installation	Wallmount
Motor	1 x 250W
Max Airflow	920m <sup>3</sup> /hr (IEC 61591)
Noise rating	52–71 dBA (IEC 60704-3)
Illumination	2 x 2W LED
Speeds	four
Supplied Accessories	3 x stainless steel grease filters
Optional Accessories	Charcoal filter part #112.0157.240
Ducting Options	Duct to atmosphere / recirculate – 150mm diameter ducting required
Power	220–240V, 50Hz 10A (3-pin plug)
Warranty	Two years parts and labour

**SHW610X1**  
60CM WALLMOUNT CANOPY RANGEHOOD

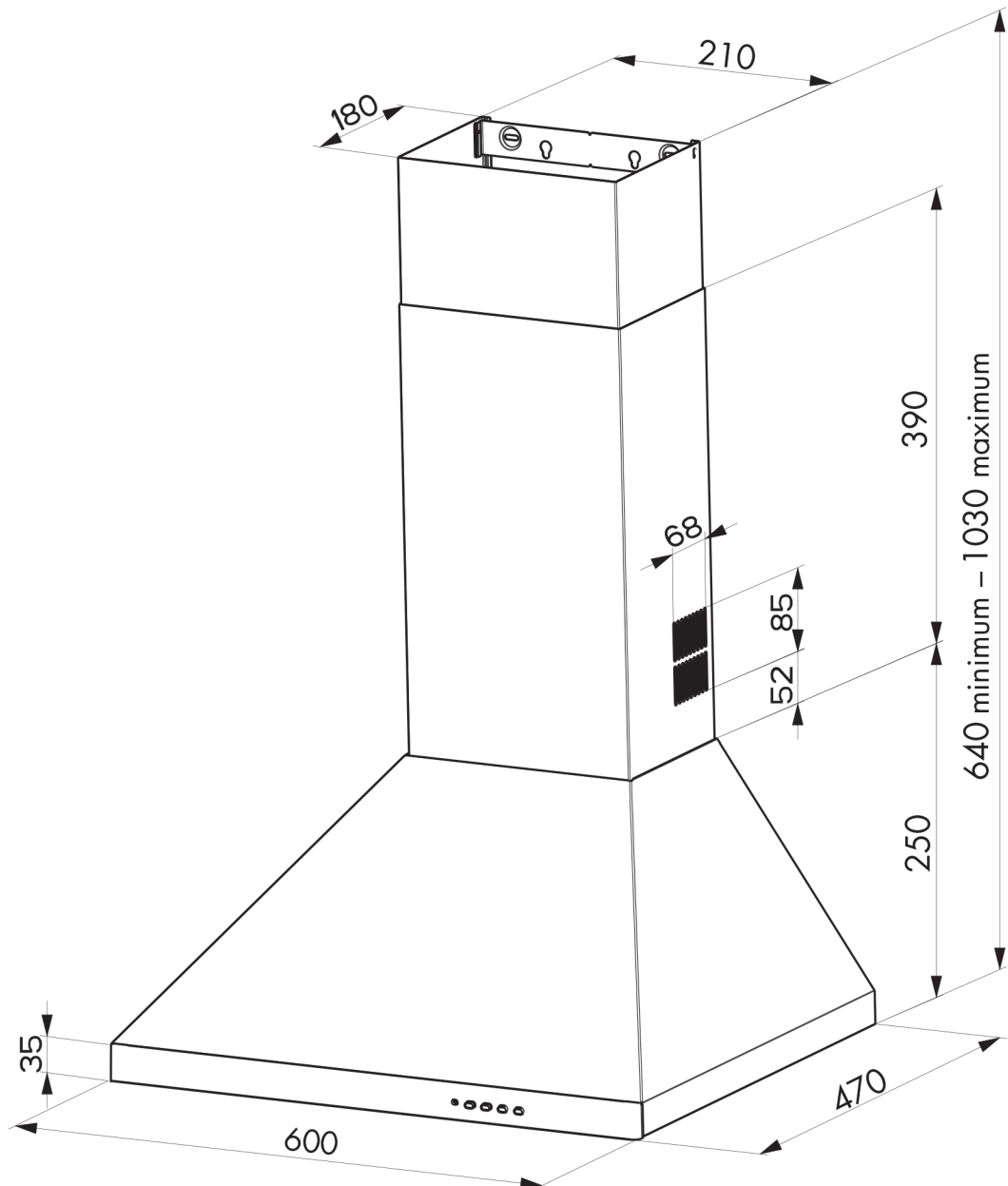

PLEASE NOTE: drawings are not to scale. They are to assist only.  
 WARNING: technical specifications and product sizes can be varied by the manufacturer without notice.  
 Cutouts for appliances should only be by physical product measurements. The above information is indicative only.

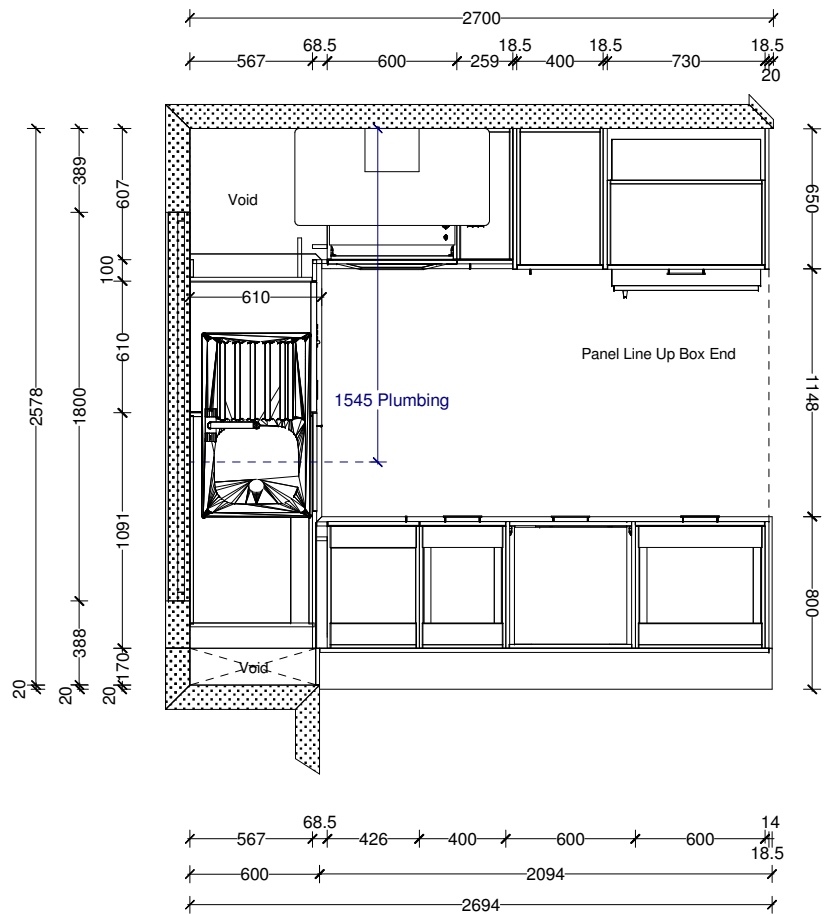

All dimensions are subject to verification onsite and adjustments of up to 100mm will be made to fit the job site at the discretion of Hostess Joinery Limited. Changes of more than 100mm on any wall will require further consultation. All appliances, rangehoods, sinks, bowls, tapware, bins, and splashbacks shown on any plan, elevation, or 3D drawing are for display purposes only. None of these items will be supplied by Hostess Joinery Limited unless specified in the quote. This page is not part of the quote.

  <p>www.hostess.co.nz</p>	<p>Job No: 23349 Version: 1 Date: 02/03/2022 Not to scale</p>	<p>Iconic Construction Ltd Lot 1 Unit 9 Mary Street Concept</p>	<p>Signed: _____ Date: _____</p>	<p>Designer: Jessie Drawn: ZY Sheet 1 of 5</p>	<p>© Hostess Joinery Limited All drawings are Copyright and remain the property of Hostess Joinery Limited. All colours and textures in 3D renders are representative only and may not be accurate.</p>
---	---	---	--------------------------------------	--	---



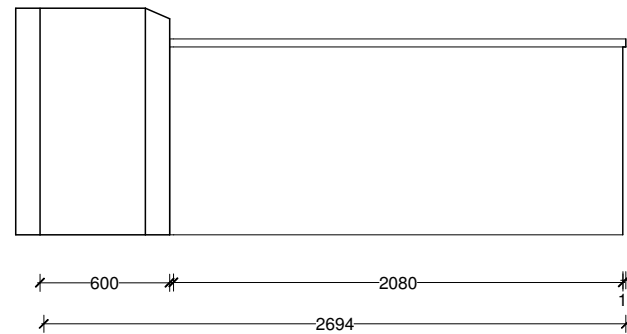
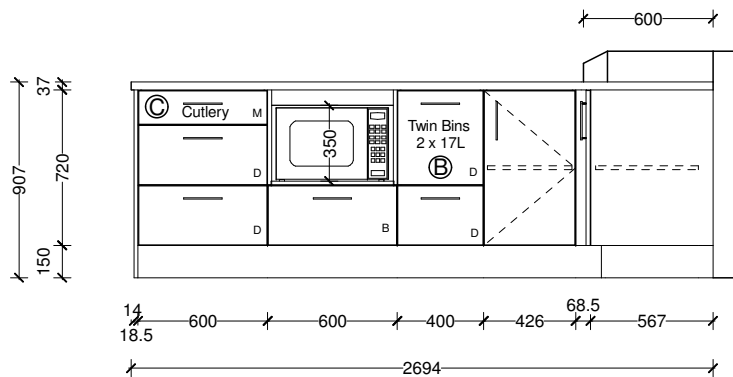
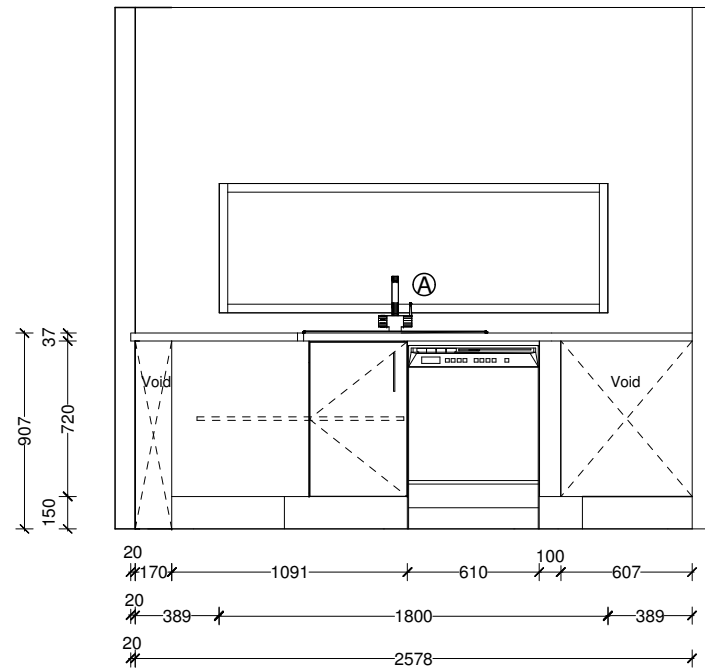
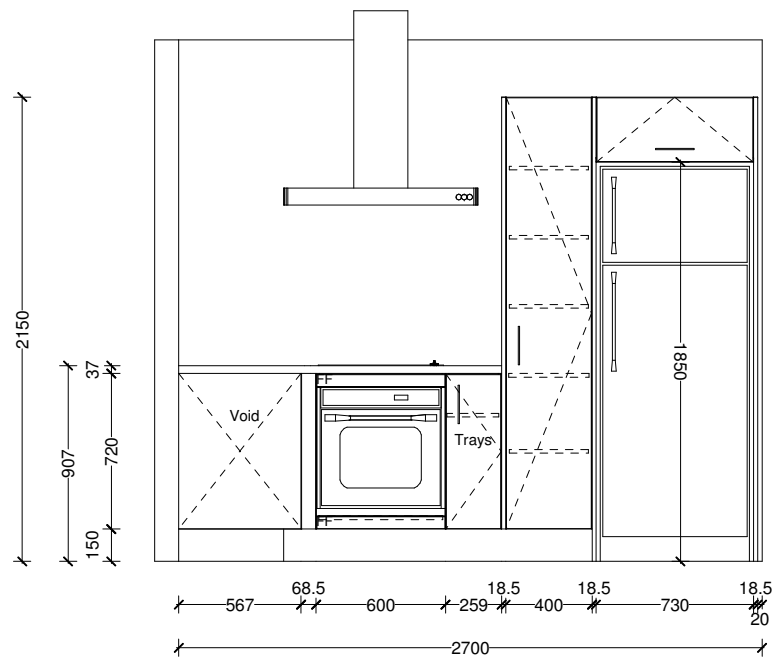

Tandemblox Drawer Box Heights  
M =86mm B =137mm D =201mm

All dimensions are subject to verification onsite and adjustments of up to 100mm will be made to fit the job site at the discretion of Hostess Joinery Limited. Changes of more than 100mm on any wall will require further consultation. All appliances, rangehoods, sinks, bowls, tapware, bins, and splashbacks shown on any plan, elevation, or 3D drawing are for display purposes only. None of these items will be supplied by Hostess Joinery Limited unless specified in the quote. This page is not part of the quote.

  <p>www.hostess.co.nz</p>	<p>Job No: 23349 Version: 1 Date: 02/03/2022 Not to scale</p>	<p>Iconic Construction Ltd Lot 1 Unit 9 Mary Street Concept</p>	<p>Signed: _____ Date: _____</p>	<p>Designer: Jessie Drawn: ZY Sheet 2 of 5</p>	<p>© Hostess Joinery Limited All drawings are Copyright and remain the property of Hostess Joinery Limited. All colours and textures in 3D renders are representative only and may not be accurate.</p>
---	---	---	--------------------------------------	--	---



All dimensions are subject to verification onsite and adjustments of up to 100mm will be made to fit the job site at the discretion of Hostess Joinery Limited. Changes of more than 100mm on any wall will require further consultation. All appliances, rangehoods, sinks, bowls, tapware, bins, and splashbacks shown on any plan, elevation, or 3D drawing are for display purposes only. None of these items will be supplied by Hostess Joinery Limited unless specified in the quote. This page is not part of the quote.

  <a href="http://www.hostess.co.nz">www.hostess.co.nz</a>	Job No: 23349 Version: 1 Date: 02/03/2022 Not to scale	Iconic Construction Ltd Lot 1 Unit 9 Mary Street Concept	Signed: _____ Date: _____	Designer: Jessie Drawn: ZY Sheet 3 of 5	© Hostess Joinery Limited All drawings are Copyright and remain the property of Hostess Joinery Limited. All colours and textures in 3D renders are representative only and may not be accurate.
---	---	---	------------------------------	---	---

**KEY** R10: 10mm radius edge    X: Square Edge    O: Acrylic Euro Edge    □: Unfinished Edge

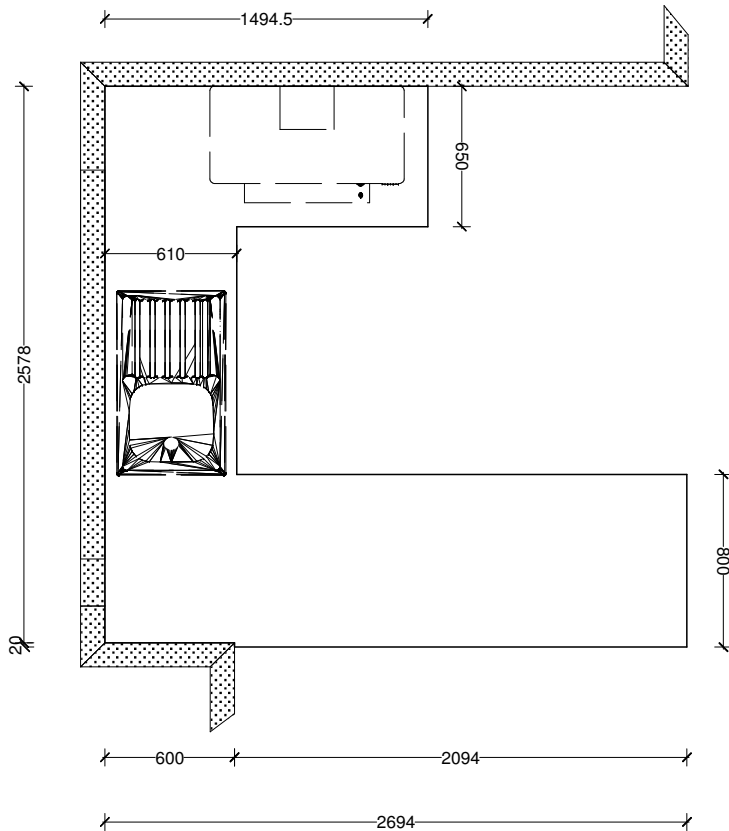

## Bench Top Quote

Quote Price:

MATERIAL  
(1st Option):

(2nd Option):

THICKNESS:

EDGE PROFILE:

BOWL TYPE:

BOWL BY HOSTESS: Y / N

BOWL CUTOUT: Y / N

WATERFALL ENDS: Y / N

HOB CUTOUT: Y / N

TAP HOLE CUTOUT: Y / N

AIR SWITCH: Y / N

TOP MOUNT / UNDERMOUNT

TEMPLATING REQ: Y / N

DELIVER TO SITE / HOSTESS

INSTALLATION REQ: Y / N

ACCESS REQUIREMENTS?

## Benchtop Order

COLOUR:

THICKNESS:

BOWL:

TOP MOUNT / UNDERMOUNT

DRAINER: L / R

LARGE BOWL: L / R

HOB CUTOUT:

All dimensions are subject to verification onsite and adjustments of up to 100mm will be made to fit the job site at the discretion of Hostess Joinery Limited.

Changes of more than 100mm on any wall will require further consultation. All appliances, rangehoods, sinks, bowls, tapware, bins, and splashbacks shown on any plan, elevation, or 3D drawing are for display purposes only. None of these items will be supplied by Hostess Joinery Limited unless specified in the quote. This page is not part of the quote.



www.hostess.co.nz

Job No: 23349

Version: 1

Date: 02/03/2022

Not to scale

Iconic Construction Ltd

Lot 1

Unit 9 Mary Street

Concept

Signed:

\_\_\_\_\_

Date:

\_\_\_\_\_

Designer: Jessie

Drawn: ZY

Sheet 4 of 5

© Hostess Joinery Limited

All drawings are Copyright and remain the property of Hostess Joinery Limited. All colours and textures in 3D renders are representative only and may not be accurate.

# Product Key

Note: Representations only, see drawing layout

Ⓐ Ⓑ Ⓒ Ⓓ Ⓔ Ⓕ Ⓖ Ⓗ Ⓘ ⓵ ⓶



**Heritage Nebraska 800-10**

Single Bowl with drainer  
 Bowl Size: 340mm x 400mm x 180mm  
 Length : 808mm  
 Width : 508mm

Ⓐ



**TWIN BINS 17L & 17L**

Blum Wesco 2 x 17L  
 Length : 225mm  
 Width : 304mm  
 Height : 295mm

Ⓑ

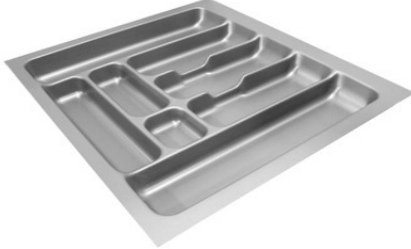

**600 Cutlery Insert**

Product code : 556.62.627  
 Suitable for 600mm drawers  
 Width : 500-540mm  
 Silver / Grey

Ⓒ

**HANDLES TBC**

All dimensions are subject to verification onsite and adjustments of up to 100mm will be made to fit the job site at the discretion of Hostess Joinery Limited. Changes of more than 100mm on any wall will require further consultation. All appliances, rangehoods, sinks, bowls, tapware, bins, and splashbacks shown on any plan, elevation, or 3D drawing are for display purposes only. None of these items will be supplied by Hostess Joinery Limited unless specified in the quote. This page is not part of the quote.

  <p>www.hostess.co.nz</p>	<p>Job No: 23349                  Version: 1                  Date: 02/03/2022                  Not to scale</p>	<p>Iconic Construction Ltd                  Lot 1                  Unit 9 Mary Street                  Concept</p>	<p>Signed: _____                  Date: _____</p>	<p>Designer: Jessie                  Drawn: ZY                  Sheet 5 of 5</p>	<p>© Hostess Joinery Limited                  All drawings are Copyright and remain the property of Hostess Joinery Limited. All colours and textures in 3D renders are representative only and may not be accurate.</p>
---	--	--	---	--	--

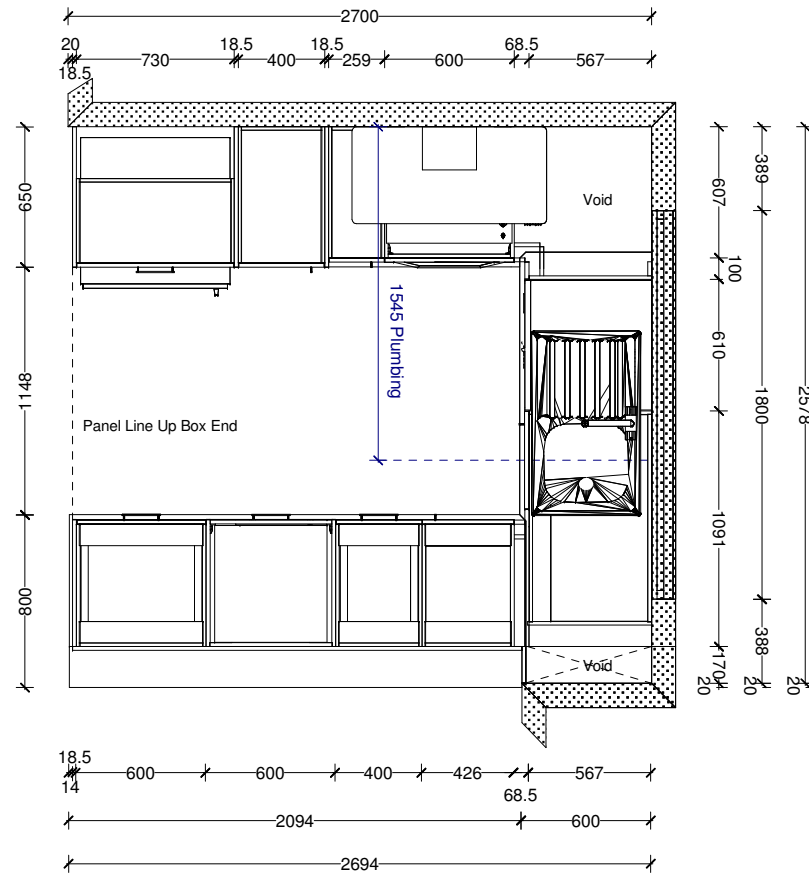

All dimensions are subject to verification onsite and adjustments of up to 100mm will be made to fit the job site at the discretion of Hostess Joinery Limited. Changes of more than 100mm on any wall will require further consultation. All appliances, rangehoods, sinks, bowls, tapware, bins, and splashbacks shown on any plan, elevation, or 3D drawing are for display purposes only. None of these items will be supplied by Hostess Joinery Limited unless specified in the quote. This page is not part of the quote.

  <p>www.hostess.co.nz</p>	<p>Job No: 23350 Version: 1 Date: 02/03/2022 Not to scale</p>	<p>Iconic Construction Ltd Lot 2 Unit 10 Mary Street Concept</p>	<p>Signed: _____ Date: _____</p>	<p>Designer: Jessie Drawn: ZY Sheet 1 of 5</p>	<p>© Hostess Joinery Limited All drawings are Copyright and remain the property of Hostess Joinery Limited. All colours and textures in 3D renders are representative only and may not be accurate.</p>
---	---	--	--------------------------------------	--	---

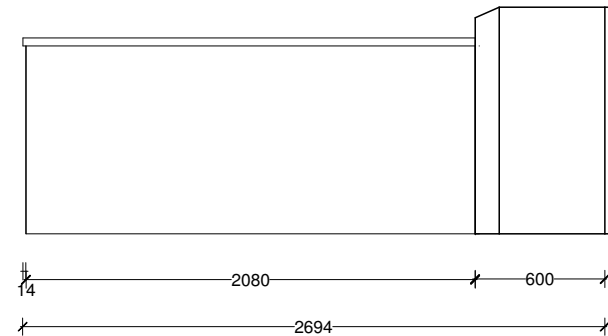
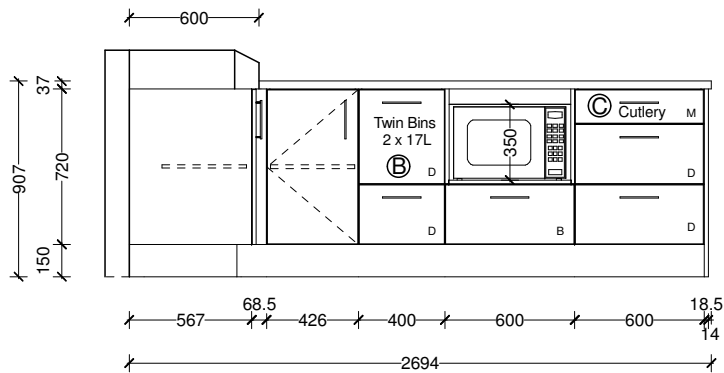
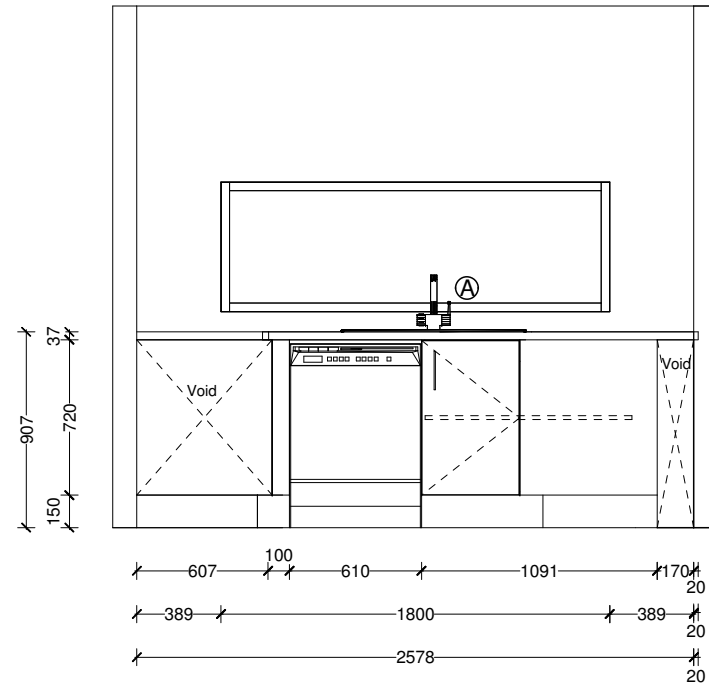
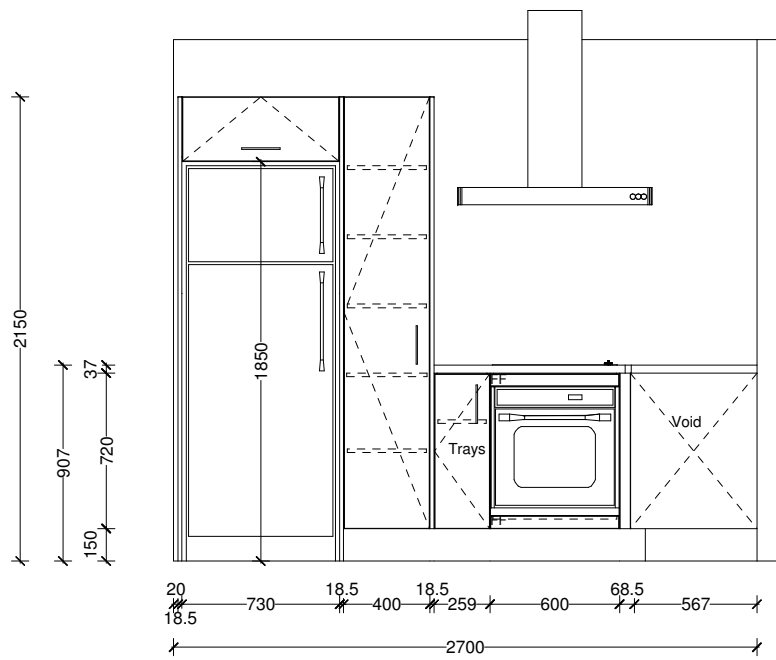

Tandembox Drawer Box Heights  
M =86mm B =137mm D =201mm

All dimensions are subject to verification onsite and adjustments of up to 100mm will be made to fit the job site at the discretion of Hostess Joinery Limited. Changes of more than 100mm on any wall will require further consultation. All appliances, rangehoods, sinks, bowls, tapware, bins, and splashbacks shown on any plan, elevation, or 3D drawing are for display purposes only. None of these items will be supplied by Hostess Joinery Limited unless specified in the quote. This page is not part of the quote.

  <p>www.hostess.co.nz</p>	<p>Job No: 23350 Version: 1 Date: 02/03/2022 Not to scale</p>	<p>Iconic Construction Ltd Lot 2 Unit 10 Mary Street Concept</p>	<p>Signed: _____ Date: _____</p>	<p>Designer: Jessie Drawn: ZY Sheet 2 of 5</p>	<p>© Hostess Joinery Limited All drawings are Copyright and remain the property of Hostess Joinery Limited. All colours and textures in 3D renders are representative only and may not be accurate.</p>
---	---	--	--------------------------------------	--	---





All dimensions are subject to verification onsite and adjustments of up to 100mm will be made to fit the job site at the discretion of Hostess Joinery Limited. Changes of more than 100mm on any wall will require further consultation. All appliances, rangehoods, sinks, bowls, tapware, bins, and splashbacks shown on any plan, elevation, or 3D drawing are for display purposes only. None of these items will be supplied by Hostess Joinery Limited unless specified in the quote. This page is not part of the quote.

  <a href="http://www.hostess.co.nz">www.hostess.co.nz</a>	Job No: 23350 Version: 1 Date: 02/03/2022 Not to scale	Iconic Construction Ltd Lot 2 Unit 10 Mary Street Concept	Signed: _____ Date: _____	Designer: Jessie Drawn: ZY Sheet 3 of 5	© Hostess Joinery Limited All drawings are Copyright and remain the property of Hostess Joinery Limited. All colours and textures in 3D renders are representative only and may not be accurate.
---	---	--	------------------------------	---	---

**KEY** R10: 10mm radius edge    X: Square Edge    O: Acrylic Euro Edge    □: Unfinished Edge

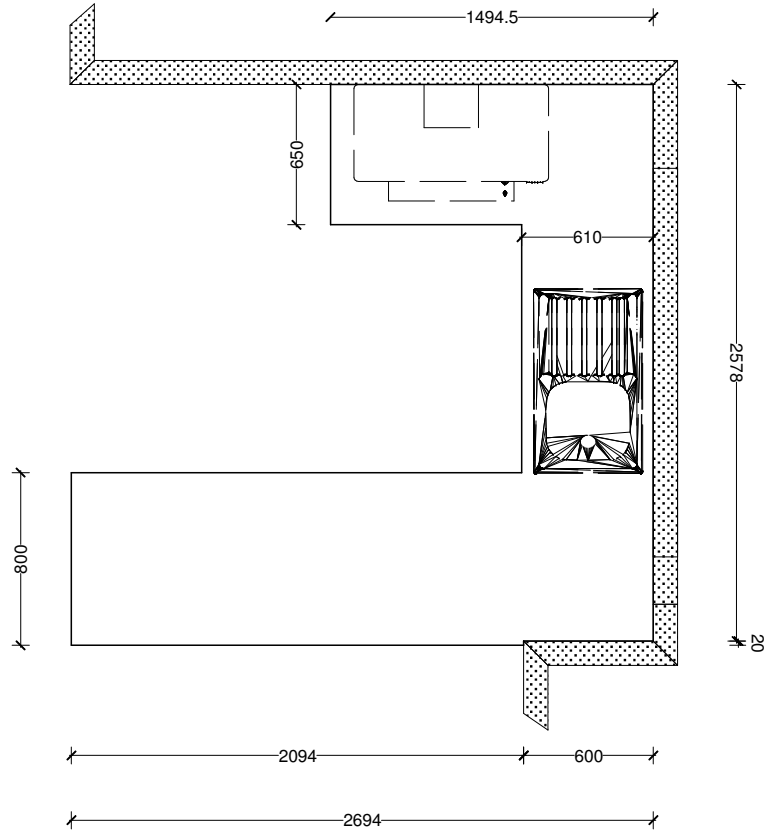

### Bench Top Quote

Quote Price:

MATERIAL (1st Option):  
 (2nd Option):  
 THICKNESS:  
 EDGE PROFILE:  
 BOWL TYPE:  
 BOWL BY HOSTESS: Y / N  
 BOWL CUTOUT: Y / N  
 WATERFALL ENDS: Y / N

HOB CUTOUT: Y / N  
 TAP HOLE CUTOUT: Y / N  
 AIR SWITCH: Y / N  
 TOP MOUNT / UNDERMOUNT  
 TEMPLATING REQ: Y / N  
 DELIVER TO SITE / HOSTESS  
 INSTALLATION REQ: Y / N  
 ACCESS REQUIREMENTS?

### Benchtop Order

COLOUR:  
 THICKNESS:  
 BOWL:  
 TOP MOUNT / UNDERMOUNT  
 DRAINER: L / R  
 LARGE BOWL: L / R  
 HOB CUTOUT:

All dimensions are subject to verification onsite and adjustments of up to 100mm will be made to fit the job site at the discretion of Hostess Joinery Limited. Changes of more than 100mm on any wall will require further consultation. All appliances, rangehoods, sinks, bowls, tapware, bins, and splashbacks shown on any plan, elevation, or 3D drawing are for display purposes only. None of these items will be supplied by Hostess Joinery Limited unless specified in the quote. This page is not part of the quote.

  <p>www.hostess.co.nz</p>	<p>Job No: 23350          Version: 1          Date: 02/03/2022          Not to scale</p>	<p>Iconic Construction Ltd          Lot 2          Unit 10 Mary Street          Concept</p>	<p>Signed: _____          Date: _____</p>	<p>Designer: Jessie          Drawn: ZY          Sheet 4 of 5</p>	<p>© Hostess Joinery Limited          All drawings are Copyright and remain the property of Hostess Joinery Limited. All colours and textures in 3D renders are representative only and may not be accurate.</p>
---	--	---	---	--	--

# Product Key

Note: Representations only, see drawing layout

Ⓐ Ⓑ Ⓒ Ⓓ Ⓔ Ⓕ Ⓖ Ⓗ Ⓘ ⓵ ⓶



**Heritage Nebraska 800-10**

Single Bowl with drainer  
 Bowl Size: 340mm x 400mm x 180mm  
 Length : 808mm  
 Width : 508mm

Ⓐ



**TWIN BINS 17L & 17L**

Blum Wesco 2 x 17L  
 Length : 225mm  
 Width : 304mm  
 Height : 295mm

Ⓑ

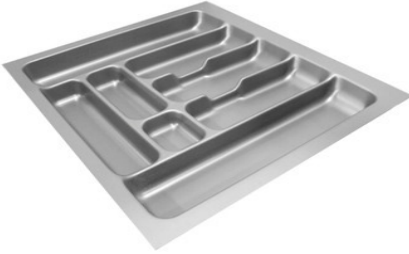

**600 Cutlery Insert**

Product code : 556.62.627  
 Suitable for 600mm drawers  
 Width : 500-540mm  
 Silver / Grey

Ⓒ

**HANDLES TBC**

All dimensions are subject to verification onsite and adjustments of up to 100mm will be made to fit the job site at the discretion of Hostess Joinery Limited. Changes of more than 100mm on any wall will require further consultation. All appliances, rangehoods, sinks, bowls, tapware, bins, and splashbacks shown on any plan, elevation, or 3D drawing are for display purposes only. None of these items will be supplied by Hostess Joinery Limited unless specified in the quote. This page is not part of the quote.

  <p>www.hostess.co.nz</p>	<p>Job No: 23350                  Version: 1                  Date: 02/03/2022                  Not to scale</p>	<p>Iconic Construction Ltd                  Lot 2                  Unit 10 Mary Street                  Concept</p>	<p>Signed: _____                  Date: _____</p>	<p>Designer: Jessie                  Drawn: ZY                  Sheet 5 of 5</p>	<p>© Hostess Joinery Limited                  All drawings are Copyright and remain the property of Hostess Joinery Limited. All colours and textures in 3D renders are representative only and may not be accurate.</p>
---	--	---	---	--	--



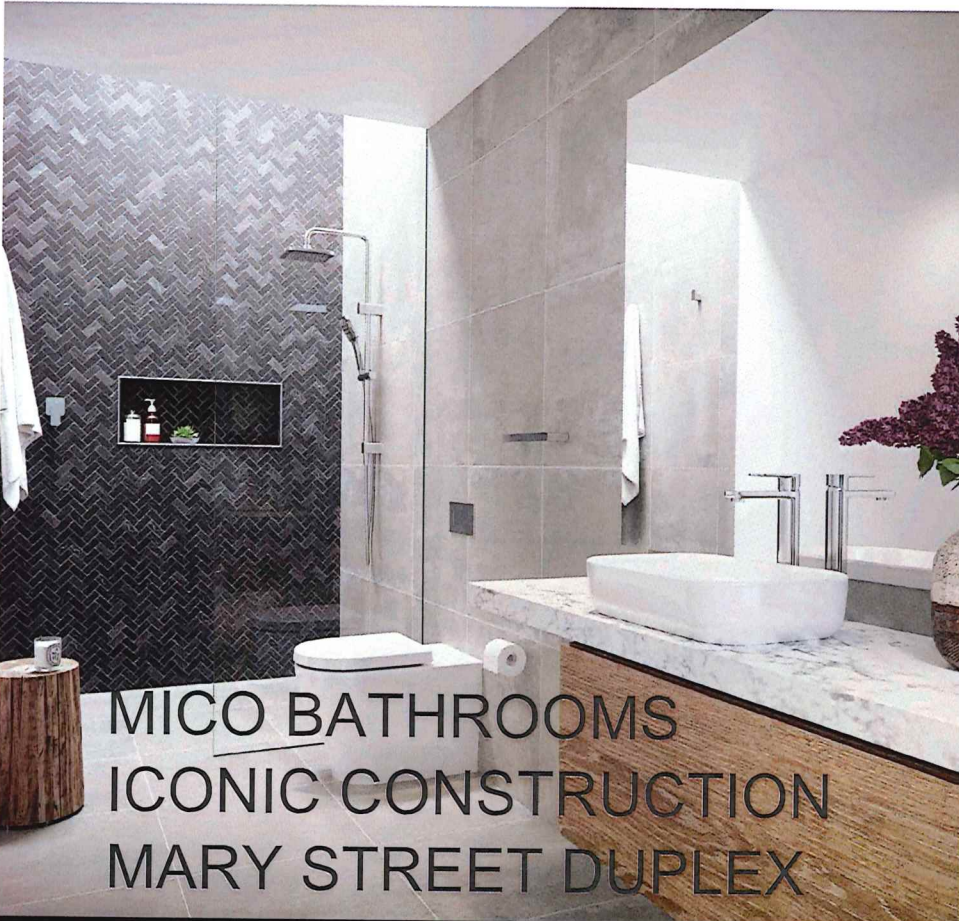
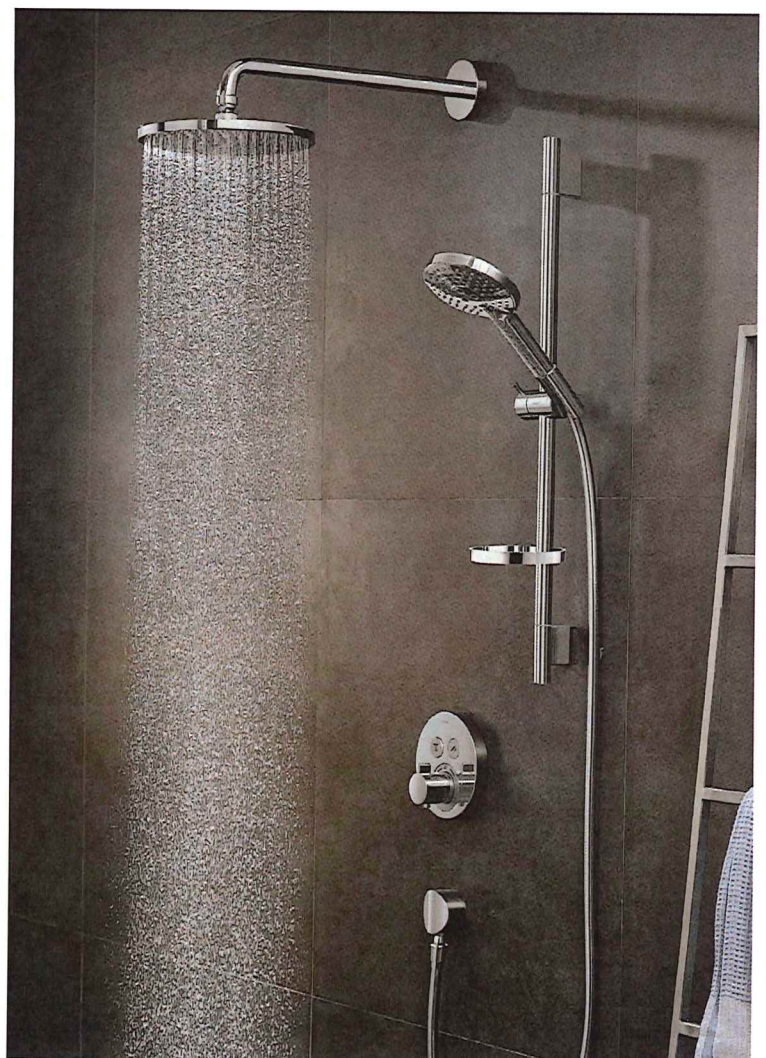

MICO BATHROOMS  
ICONIC CONSTRUCTION  
MARY STREET DUPLEX



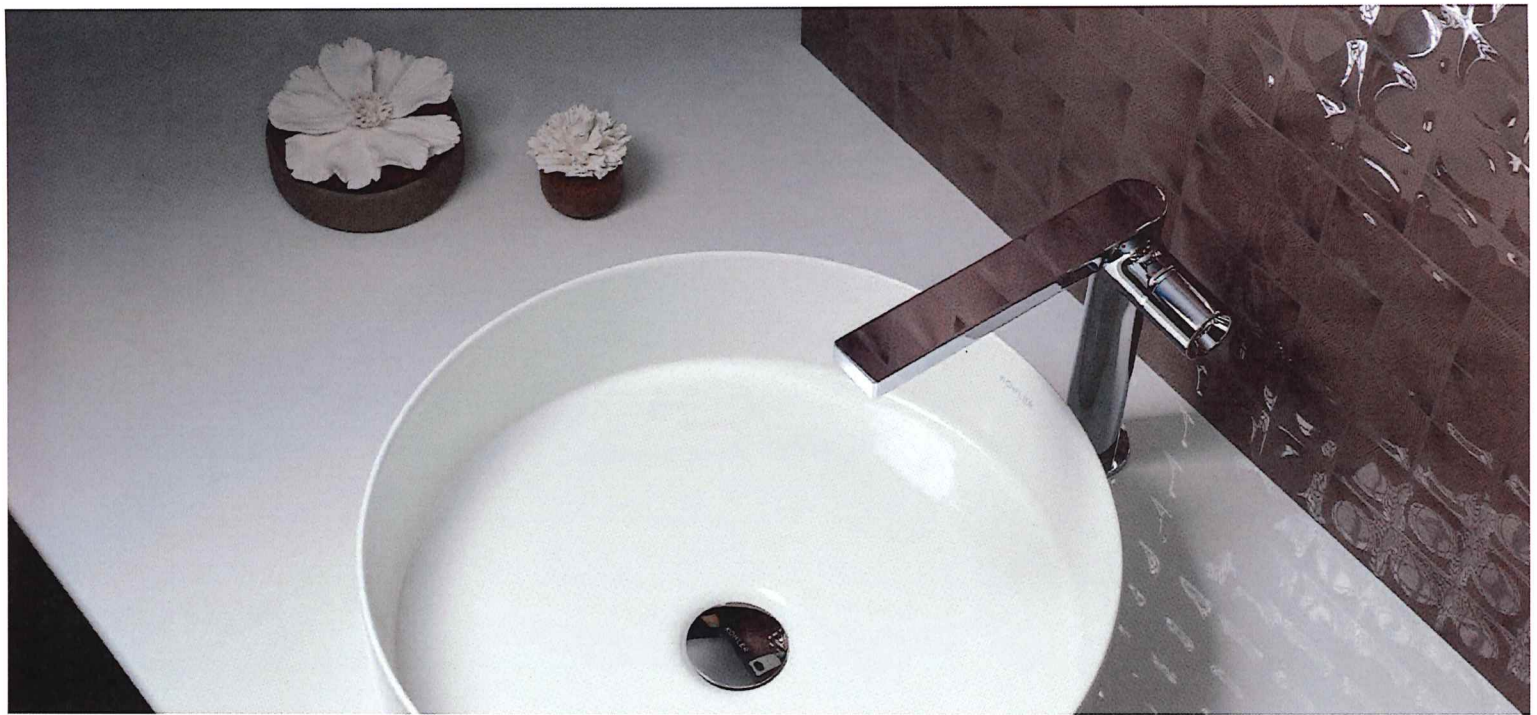

## *About Mico*

Mico is New Zealand's leading plumbing, bathroom, heating and laundry specialist.

### *Bathrooms:* ONLY THE BEST WILL DO

A bathroom may be one of the most functional areas of a home, but there's no reason it can't also be stylish and welcoming.

At Mico, our specialists understand that there's more to a bathroom than pipes and fittings and that the perfect bathroom will make a positive difference to your day, every single day.

### *Industry* - LEADING INNOVATION

With more than 70 years of experience and over 60 branches around New Zealand, we have both the knowledge and the products to guide you through the process of crafting your dream bathroom. We offer industry-leading warranties on all our products and our focus on providing value for money is just part of what makes us one of the country's most respected and trusted bathroom suppliers.



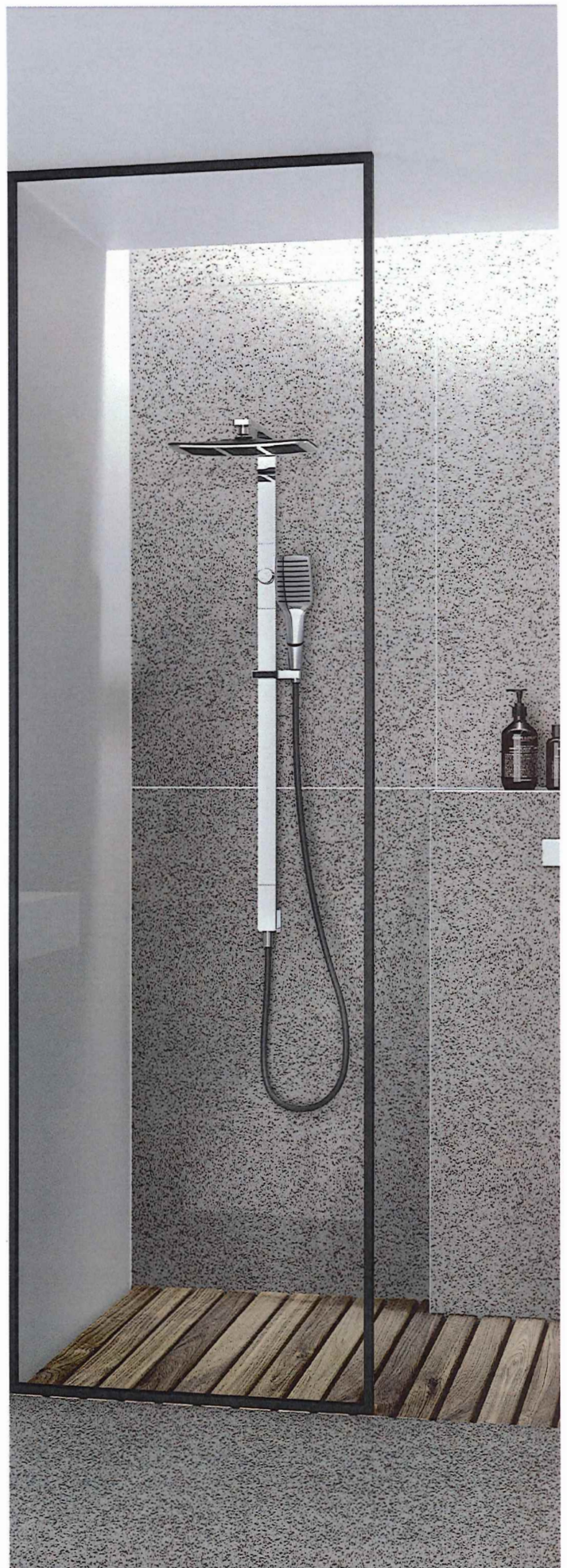



# BATHROOM

---

Brighton Framed Square 3-Sided Side Moulded Wall Shower Enclosure 900 x 900 x 1950mm Center Drain  
Fiberglass Reinforced Acrylic Chrome

Functional, elegant & stylish, White or chrome with 1950mm high shower screens,  
6mm toughened safety glass meeting all NZ standards, Fibreglass reinforced acrylic  
with a 30mm upstand, Includes an easy clean shower waste and adhesive and  
sealant pack, Showers suitable for both tiled and acrylic walls, 5 year warranty,  
Tapware and accessories not included



---

**mico** design

# SHOWERS

---

## Brighton Curved Shower 900x900

### 696768 - 900x900 Corner Moulded Wall chrome

Chrome slide moulded wall shown. Tray: fibreglass reinforced acrylic with a 30mm upstand. Includes an easy clean shower waste and adhesive & sealant pack/ Showers suitable for both tiled and acrylic walls. 1950mm door height.

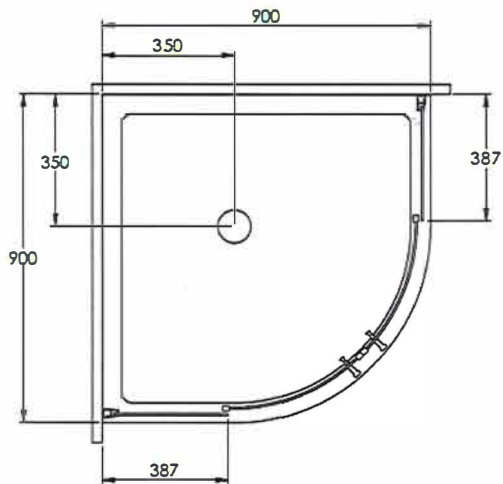
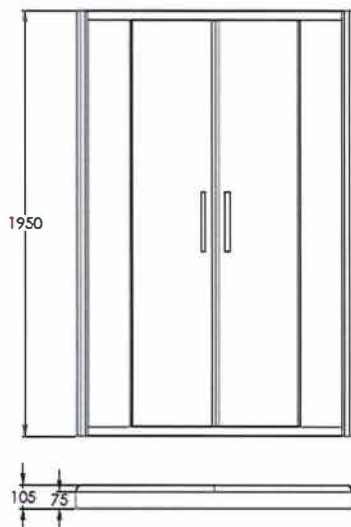
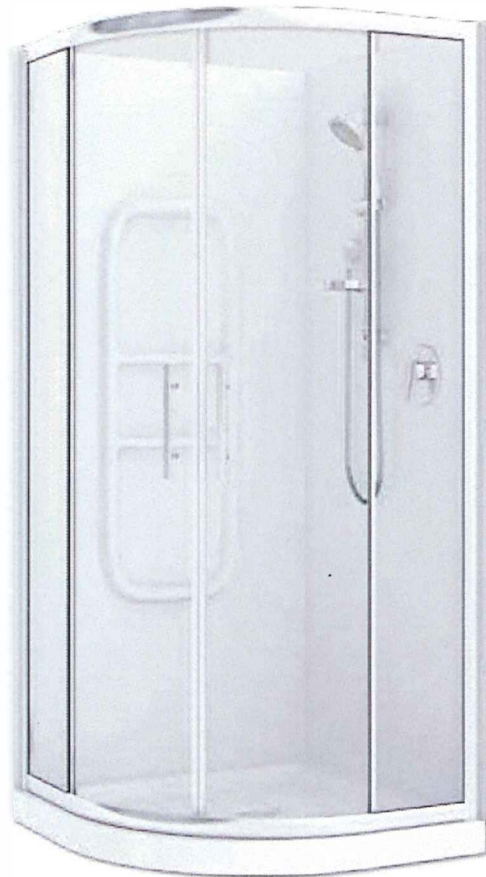

# TAPWARE

Adesso Form Shower Mixer  
719133  
Chrome Finish, All Pressure, Adjustable Isolator valves

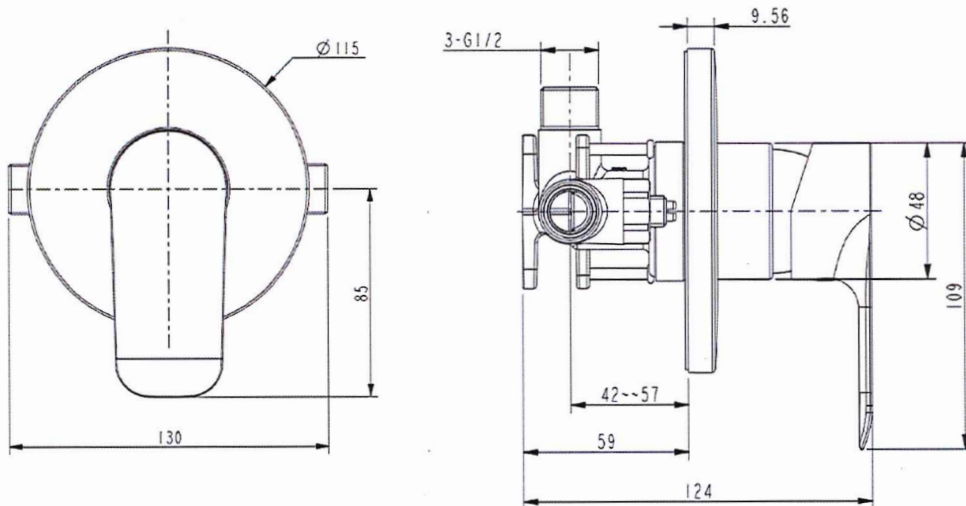

**mico** design

# TAPWARE

## Adesso Urban Accessible Slide Shower

707649

Switch three function slide shower, with polished chrome finish, 3 Function, Aqua Air water saving technology  
Mains Pressure Wels Rating 3\* - 7 l/min

Please Note: Minimum 900mm Rail Suitable for Accessible Situations

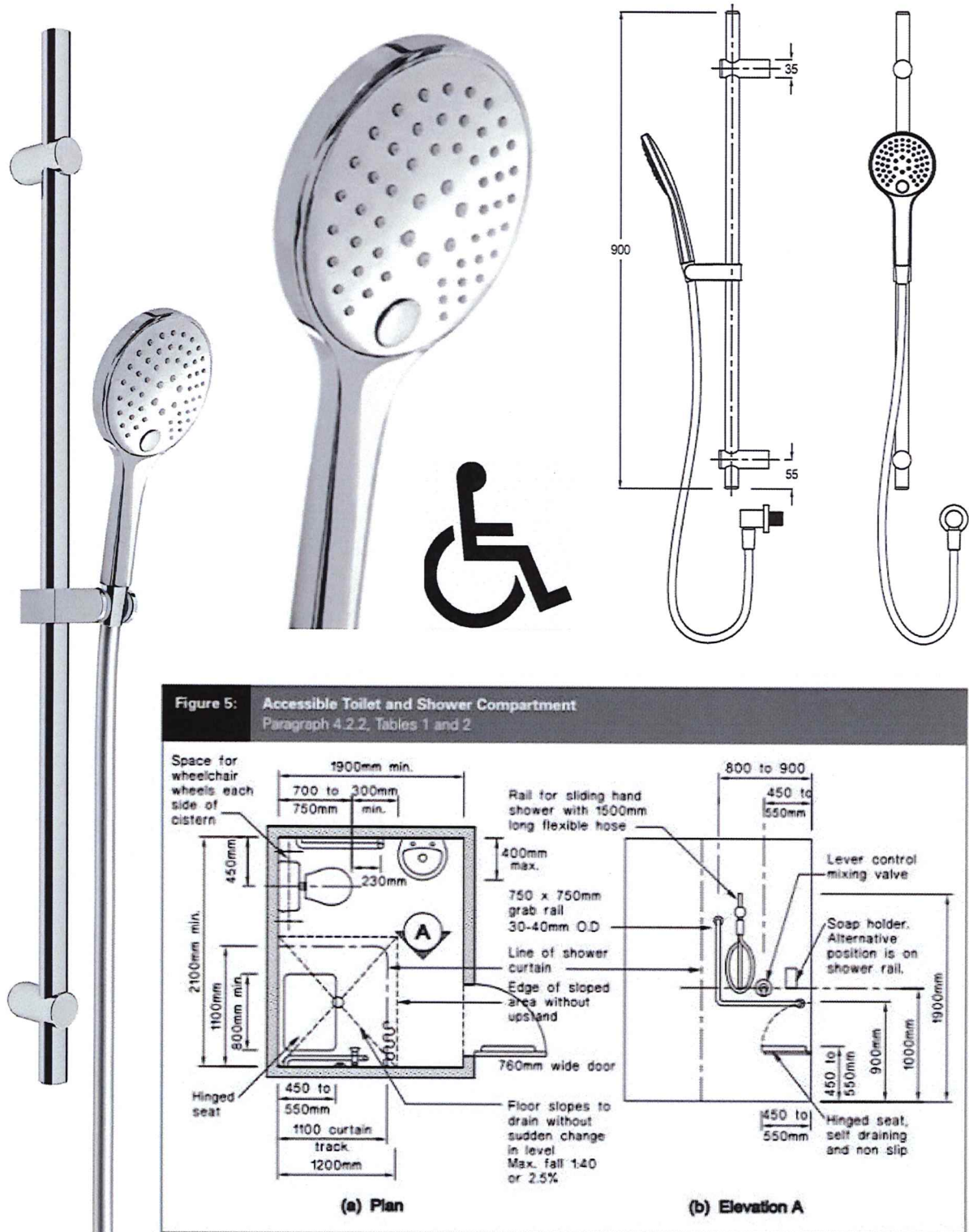

# BATHROOM

---

Rakaia Wall Hung Vanity White 450mm

582594

2 Doors, Gloss white: 2-pack urethane on MRF, Dimensions: H480 x W450 x  
D320mm



---

**mico** design

# TAPWARE

---

Adesso Form Basin Mixer  
719130

Chrome Finish, All Pressure, 5-star Mains Pressure, 5-star Unequal Pressure

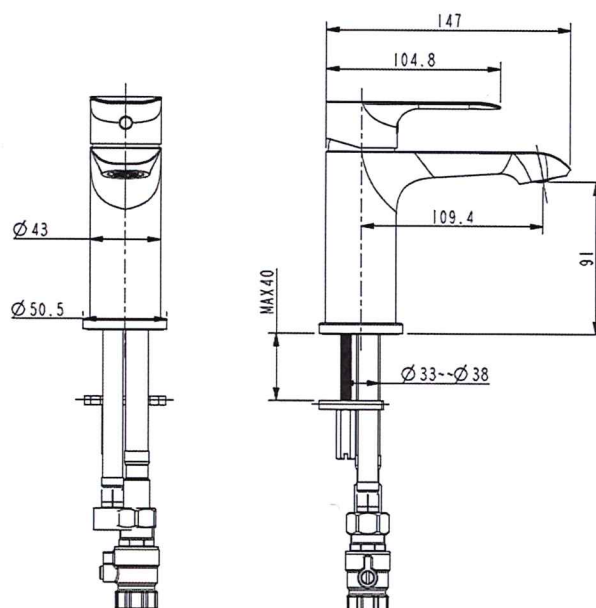

---

**mico** design



# WASTES & TRAPS

Pop-Up Waste With Overflow 32mm  
636725  
Choice of flush or domed plug included

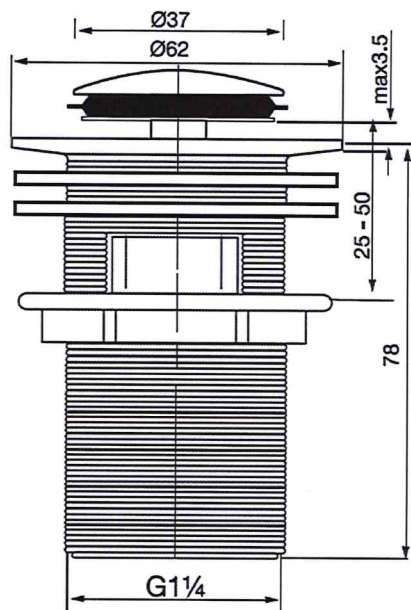
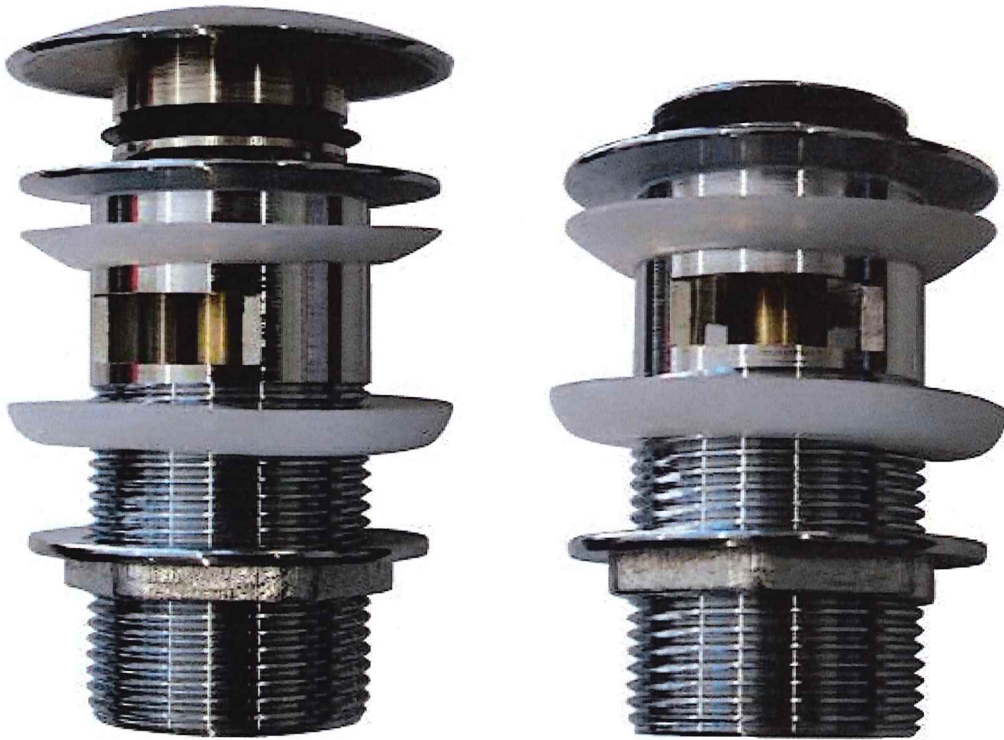

**mico**



BATHROOMWARE  
FOR REAL KIWIS  
**Raymor**

# ATLANTA II TOILET SUITE

The Atlanta range has European style, that will add an air of sophistication to your bathroom. On trend with soft edging, this range enhances the look of any bathroom. Atlanta's fresh design not only makes it appealing to look at but also very easy to clean with new rimless pan technology.

ATLANTA II STANDARD SEAT  
(7)741380



ATLANTA II SLIM SEAT  
(7)741381

FEATURES

- Full vitreous china back to wall suit featuring a rimless pan and dual flush cistern
- Soft close and quick release toilet seat
- WDI inlet valve
- WELS 4★ rated 3.5L per average flush
- Back entry - options for left and right bottom entry

S Trap set out 65 – 175mm

P Trap set out 185mm

Vario trap available separately

160mm – 270mm (7)706626

SPECIFICATION

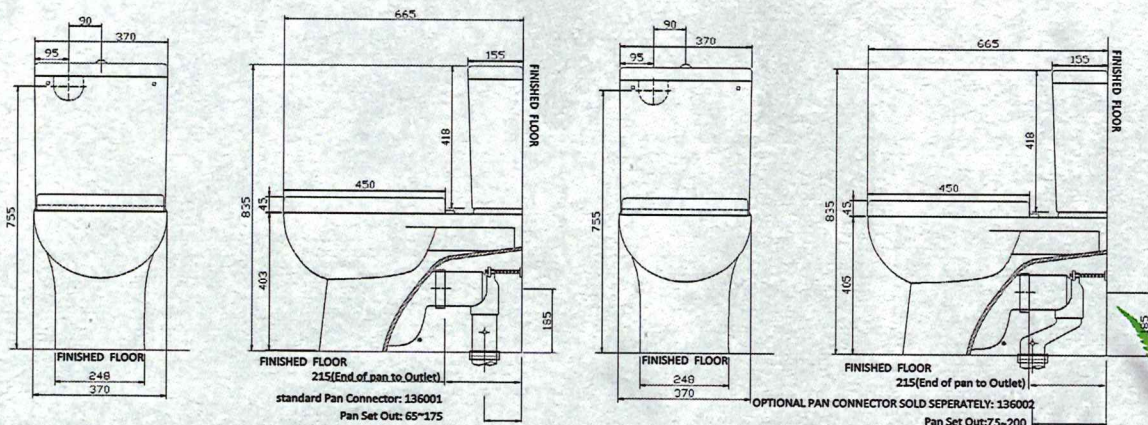

WASTES, TAPWARE AND ACCESSORIES NOT INCLUDED



www.placemakers.co.nz

**mico**

The bathroom specialist

www.mico.co.nz





# BATHROOM

---

Boston II Toilet Roll Holder Chrome

729014

Solid brass construction, Easy to install, Fixing kit included, Stable structure, Bright chrome finish



---

**mico** design

# TOWEL RAIL

## R-Series Round 7 Rail 620194

Dimensions: W 600mm x H 805mm x D122mm

Modern minimalist design, IP45 rating for use in Zone 1 - able to be positioned almost anywhere in the bathroom.  
AS/NZS 60335 compliant, Dual wiring: power connection available on left or right

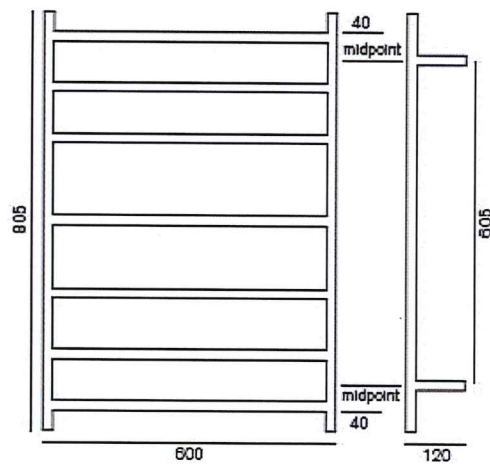

Model	Code	Finish	IP Rating	Rails	Height	Width	Depth	Width Centres	Vertical Centres	Watts	Concealed Wire	Dual Wire
R805	(7)620194	S/S	IP45	7	805	600	120	570	605	88	Yes	Yes

# TAPWARE

---

## Adesso Form Kitchen Mixer 719132

Gun Metal Finish, All Pressure, 5-star Mains Pressure, 4-star Unequal Pressure

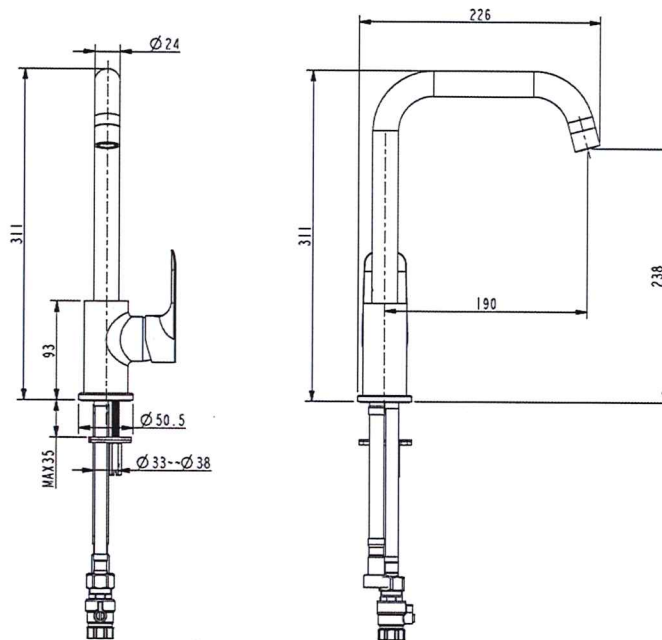

---

**mico** design

## Description

ROBINHOOD STANDARD SUPERTUB WITH S/S GOOSENECK TAP  
 ST3101X



## Dimensions

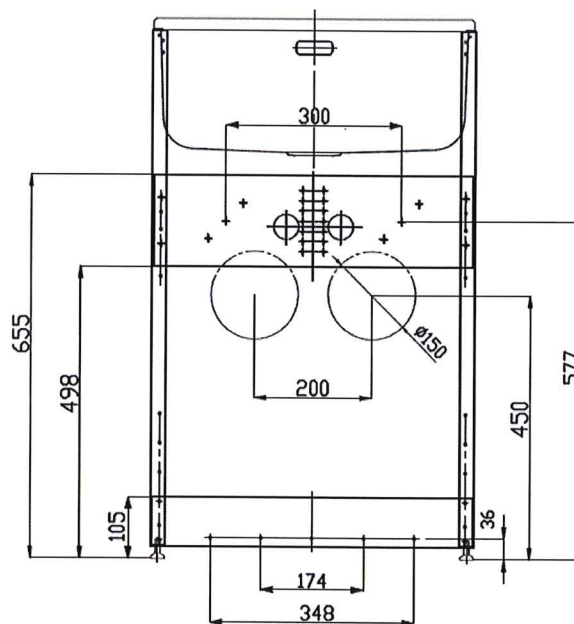
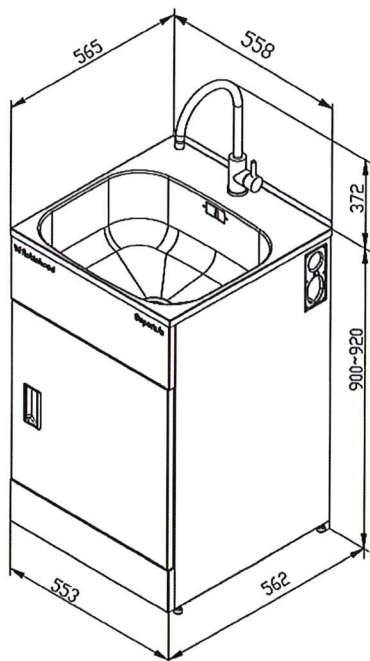

Dated 13/06/2022

## Specifications

### Tapware

Tapware type	#304 Stainless Steel Gooseneck Tap
WELS rating	5 Stars, 5.5L per minute
Max & Min pressure	Maximum pressure 72.5 PSI (500 kPa); Minimum pressure 22 PSI (150 kPa)
Temperature range	Recommended temperature range 5° to 65°C; Maximum temperature 80°C

### Sink

Bowl type	0.8mm polished #304 Stainless Steel
Bowl capacity	38L gross capacity measured to the top; 30L capacity to overflow
Waste type/ discharge flow rate	Plug waste/ 60L per minute
Overflow/ Flow rate	Yes/ 30L per minute

### Cabinet

Handle type	Recessed plastic handle
Door opening	Reversible, can be either left or right hand opening
Adjustable levelling feet	Yes
Side apertures for hoses	Yes, on both sides
3 Way ball valves isolators	Yes, included
Washing machine waste pipe	Separate
Cabinet color/finish	Satin white powder coated
Cabinet material	0.6mm galvanized steel
Maximum height of items can be stored	510mm

### Dimensions & Weights

Product dimensions (mm)	W558*D565*H(900-920)
Carton dimensions (mm)	W575*D585*H965
Gross/Net weight (Kg)	21/18

### Warranty

Tapware & Cabinet	2 years on parts & labour from the date of purchase
Sink	5 years on parts & labour from the date of purchase



# SPECIFICATIONS

## MAINS PRESSURE – VITREOUS ENAMEL (VE)

Product		Models											
Single Element Indoor		31202519V	31204515	31209015	31213513	32213515	31218013		32218015	31225015	31230015		
			31204513	31209013	31213515		31218015						
Twin Element (non-simultaneous) Indoor							31218025			31225025			
Dual Element (simultaneous) Indoor											31230033		
											31230055		
Optima Outdoor/Indoor							91318015						
Optima Twin Element (non-simultaneous) Outdoor/Indoor												91330025	492400G8
Approx. Storage Capacity	Litres	25	45	90	135	135	180	180	180	250	300	300	400
Boost Capacity (Twin Element)	Litres	-	-	-	-	-	45*	-	-	50**	50	47	90
Height	A (mm)	398	525	925	1325	935	1710	1720	1165	1555	1815	1820	1840
Width	B (mm)	400	490	490	490	580	490	490	580	580	580	580	690
	C (mm)	116	120	120	120	120	120	120	120	120	120	120	120
	D (mm)	32	65	65	65	65	65	-	65	65	65	-	105
	E (mm)	-	-	-	-	-	-	-	-	-	-	162	-
	F (mm)	-	-	-	-	-	1182*	-	-	1126**	-	1298	1323
	G (mm)	246	-	-	-	-	-	1546	-	-	-	1636	1479
	H (°)	45	45	45	45	45	45	36	45	45	45	36	97
Approx Weight Empty	Kg	15	26	38	49	54	60-62	64	64	80-82	91	97	113
TPR Valve Setting	kPa	1000	1000	1000	1000	1000	1000	1000	1000	1000	1000	1000	1000
Water Connections		RP ¾ /20	RP ¾ /20	RP ¾ /20	RP ¾ /20	RP ¾ /20	RP ¾ /20	RP ¾ /20	RP ¾ /20	RP ¾ /20	RP ¾ /20	RP ¾ /20	RP ¾ /20
Element Rating (@230V)	kW	2.0	2.0 or 3.0	2.0 or 3.0	2.0 or 3.0	3.0	2.0 or 3.0	3.0	3.0	3.0	3.0 or 5.0	3.0	4.8*

\*31218025 only \*\*31225025 only ^ @ 240V

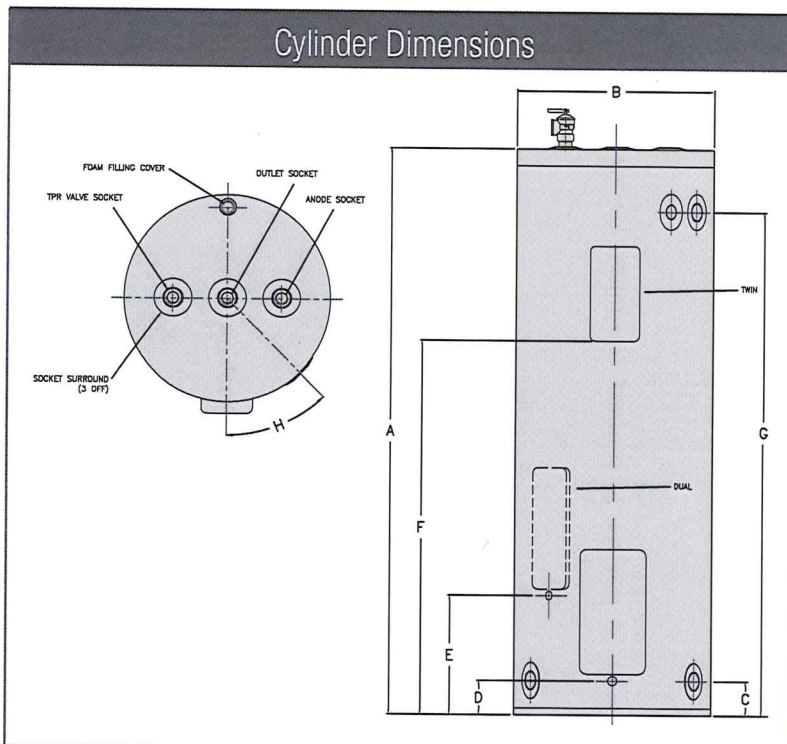

1. Inlet/Outlet and TPR valve are side mounted on left-hand side of 31202519V.
2. Inlet/Outlet and TPR valve are side mounted on right-hand side of 91318015 and 91330025.

### Specifications Electric (@230V)

kW	Recovery on a 50°C rise	AMPS
2.0 kW	34 litres per hr	8.7 A
2.4 kW	40 litres per hr	10.4 A
3.0 kW	51 litres per hr	13.1 A
3.6 kW	62 litres per hr	15.7 A
4.8 kW	82 litres per hr	21.0 A
5.0 kW	85 litres per hr	21.8 A
6.0 kW	103 litres per hr	26.1 A
2 x 3.0 kW	103 litres per hr	26.2 A
2 x 5.0 kW	171 litres per hr	43.6 A



## ACCESSORIES

---

Cylinder Tray Square  
508510  
Hot Water Cylinder Tray 540, 540mm x 540mm O/Diameter

